

SINAP[®]

Design manual



Shanghai SINAP Membrane Tech Co., Ltd

Instructions

Thank you for choose SINAP membrane.

This manual introduces in detail the design of SINAP flat sheet membrane and other aspects

For running the MBR system stably, please read this manual carefully and fully understand the contents. And please keep this manual for take reference when needed.

If have question please contact our technical staff. Tell: +86-21-66032658; E-mail: sinap@sh-sinap.com

CATALOGUE

1. SINAP FLAT SHEET MEMBRANE ELEMENT 3

 1.1 SINAP FLAT SHEET MEMBRANE ELEMENT OVERVIEW 3

 1.2 TYPE AND PARAMETERS..... 3

2. SINAP MEMBRANE MODULE..... 4

 2.1 SINAP MEMBRANE MODULE STRUCTURE..... 4

 2.2 SINAP MODULE NAME 6

 2.3 SINAP MEMBRANE MODULE SPECIFICATIONS AND PERFORMANCE 7

3. MBR PROCESS DESCRIPTION 11

4. SINAP MBR SYSTEM DESIGN PROCESS 12

5. SINAP MBR SYSTEM DESIGN..... 13

 5.1 CONFIRM INFLUENTIAL QUALITY AND QUANTITY 13

 5.2 MEMBRANE FLUX FORMULATION 16

 5.3 MEMBRANE AREA CALCULATION..... 16

 5.4 MEMBRANE ELEMENT SELECTION 16

 5.5 MEMBRANE ELEMENTS CALCULATION 18

 5.6 MEMBRANE MODULE CALCULATION..... 18

 5.7 MEMBRANE TANK SIZE CALCULATION 20

 5.8 MEMBRANE SYSTEM SUPPORT EQUIPMENT SELECTION..... 22

 5.9 MEMBRANE SYSTEM DESIGN REFERENCE 25

 5.10 MEMBRANE TANK LAYOUT 27

 5.11 WATER LEVEL AND HEIGHT OF MEMBRANE TANK 29

 5.12 MEMBRANE MODULE POSITION 31

 5.13 MEMBRANE SYSTEM PIPELINE DESIGN..... 33

 5.14 MEMBRANE SYSTEM SUPPORTING EQUIPMENT 35

 5.15 AUTONOMOUS SYSTEM 43

6. SINAP MEMBRANE MODULE LIFTING..... 46

 6.1 LIFTING HEIGHT OF MEMBRANE MODULE 46

 6.2 LIFTING LOAD OF MEMBRANE MODULE 49

7. ATTACHMENT: MEMBRANE MODULE BOUNDARY AND INSTALLATION

DIMENSIONS 50

 TABLE 7.1 SINGLE DECK MEMBRANE MODULE BOUNDARY AND INSTALLATION DIMENSIONS 51

 TABLE 7.2 DOUBLE DECK MEMBRANE MODULE BOUNDARY AND INSTALLATION DIMENSIONS 53

1. SINAP flat sheet membrane element

1.1 SINAP flat sheet membrane element overview

Flat sheet membrane mainly uses in Membrane Bio-Reactor (MBR).

Flat sheet membrane elements are formed by membrane, support layer and guide panel, a nozzle is set on the top of guide panel. Figure 1-1 is Structural diagram of membrane element.

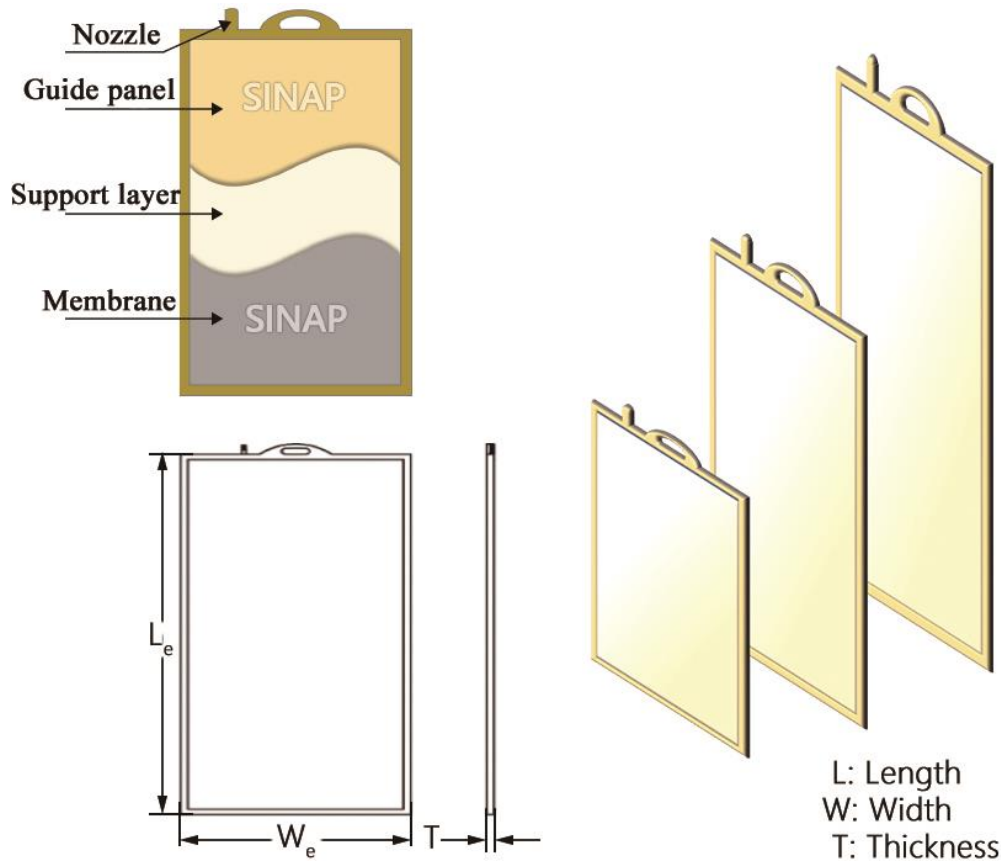

Figure 1-1 Structural diagram of membrane element

1.2 Type and Parameters

Table 1.1 Type and Parameters of SINAP membrane element

Type	Membrane area (m ²)	Dimension (mm)			Pore size (μm)	Material	Net weight (Kg)
		Le	We	T			
SINAP10	0.1	320	220	6	0.1	PVDF membrane + PET layer + ABS Panel	0.4
SINAP25	0.25	465	340	7			0.8
SINAP40	0.4	548	490	7			1.5
SINAP80	0.8	1000	490	7			3.0
SINAP100	1.0	1250	490	7			4.0
SINAP150	1.5	1750	490	7			6.0

2. SINAP membrane module

2.1 SINAP membrane module structure

The membrane module provided by SINAP consists of a membrane case and a diffuser case, See figure 2-1 (a) and (b):

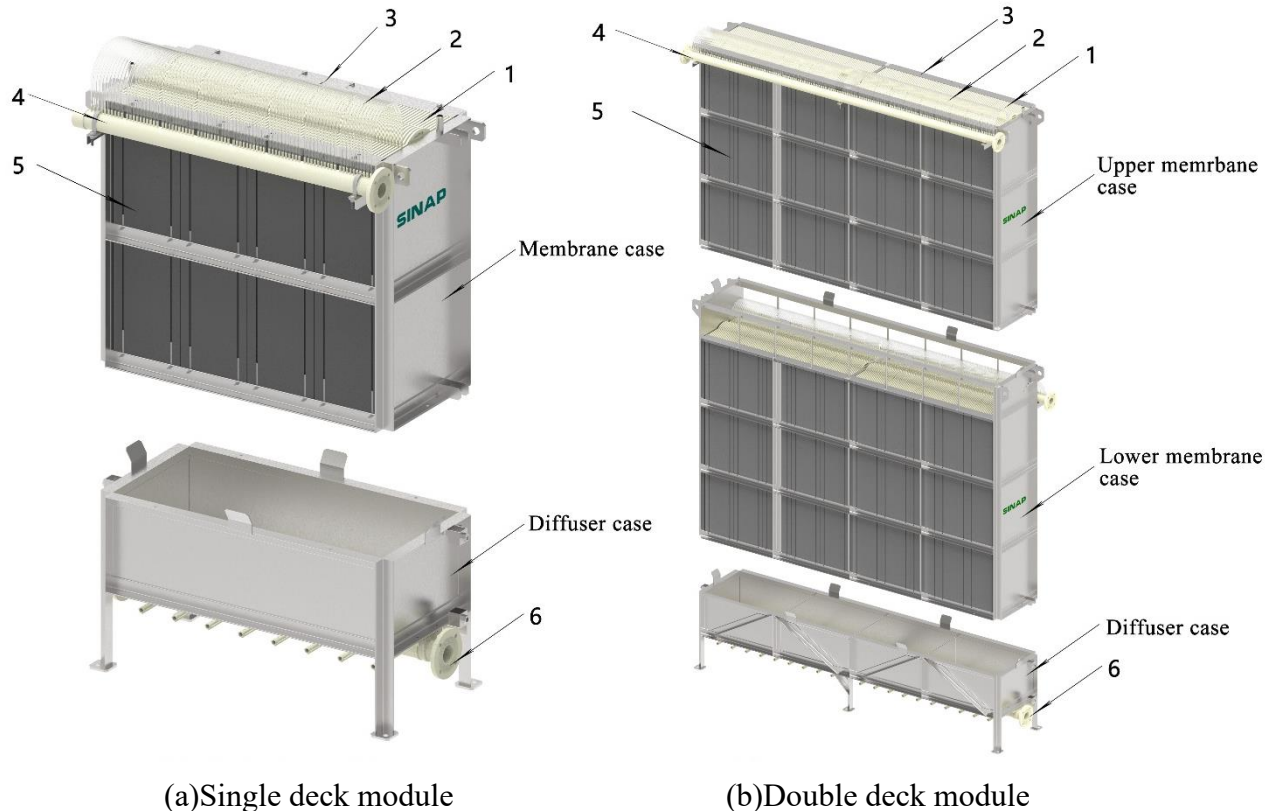

Figure 2-1 SINAP membrane module structure

◆ Membrane case:

Main function: Uniformly arranged membrane elements and collect the permeate water.

1. Membrane element: Pore diameter 0.1 μ m PVDF flat sheet membrane;
2. Hose: Connect the membrane and permeate manifold;
3. Rubbers and covers: Fix membrane elements, prevent the vibration and floating;
4. Manifold: Collect the permeate water from each membrane and connect the main permeate pipe with flange;
5. Guide plate: Fix the membrane element equidistance.

◆ Diffuser case:

Main function: Mixing the air and water evenly, to prevent membrane fouling and provide oxygen for the biochemical reactions.

6. Diffuser: Special perforated diffuser for MBR.

2.2 SINAP module name

SINAP membrane module names after the following rules.

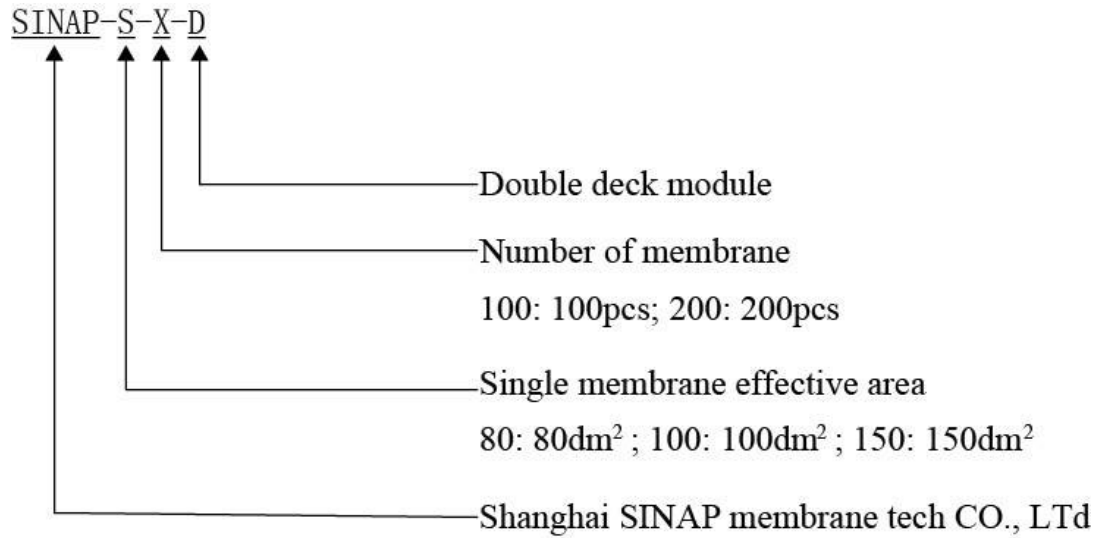

Ex.:

SINAP150-100 means:

This membrane module is made by Shanghai SINAP Membrane Tech Co., Ltd.,
Single membrane effective area is 1.5m², formed by 100 pcs.

2.3 SINAP membrane module specifications and performance

SINAP membrane module specifications and performance please check Figure 2-2 and Table 2.1, 2.2, 2.3.

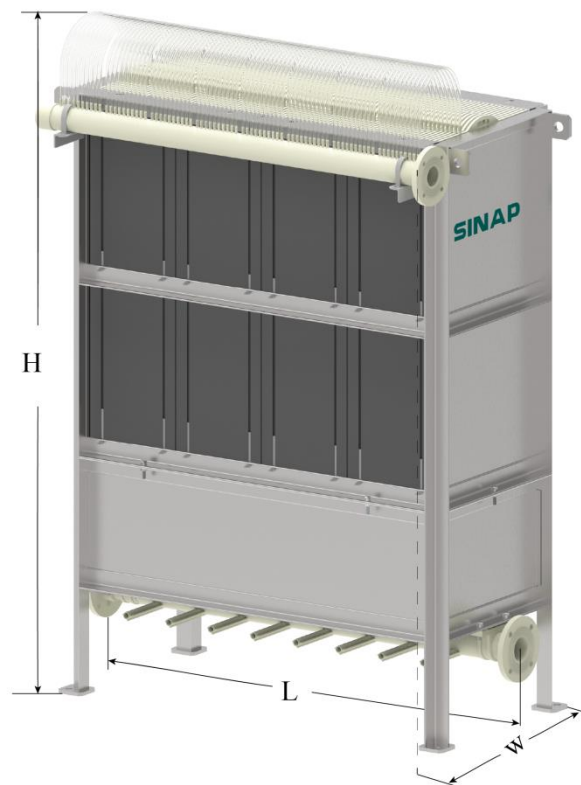

L: Length
W: Width
H: Height

Figure 2-2 Membrane module specifications

Table 2.1 Single deck module specifications*

Module Type	Single membrane area (m ²)	Number of membrane elements (pc)	Effective membrane area (m ²)	Capacity [#] (m ³ /d)	Aeration volume (m ³ /min)	Size (mm)			Weight (Kg)	Membrane case weight (Kg)	Diffuser case weight (Kg)
						L	W	H			
SINAP80-60	0.8	60	48	20-30	0.6-0.7	1090	760	1900	280	240	40
SINAP80-80		80	64	25-38	0.8-1.0	1380			360	315	45
SINAP80-100		100	80	32-48	1.0-1.2	1660			450	395	55
SINAP80-120		120	96	38-57	1.2-1.4	1940			580	520	60
SINAP80-160		160	128	51-76	1.6-2.0	2540			750	665	85
SINAP80-200		200	160	64-96	2.0-2.4	3110			920	830	90
SINAP100-60	1.0	60	60	24-36	0.6-0.7	1090	760	2150	350	310	40
SINAP100-80		80	80	32-48	0.8-1.0	1380			450	405	45
SINAP100-100		100	100	40-60	1.0-1.2	1660			560	505	55
SINAP100-120		120	120	48-72	1.2-1.4	1940			700	640	60
SINAP100-160		160	160	64-96	1.6-2.0	2540			750	665	85
SINAP100-200		200	200	80-120	2.0-2.4	3110			1160	1070	90
SINAP150-100	1.5	100	150	60-90	1.0-1.2	1660	760	2650	780	725	55
SINAP150-120		120	180	72-108	1.2-1.4	1940			920	860	60
SINAP150-160		160	240	96-144	1.6-2.0	2540			1240	1155	85
SINAP150-200		200	300	120-180	2.0-2.4	3110			1520	1430	90

* The data of membrane module listed above are for design reference only, actual size in kind prevail.

For different water quality the productivity will have a big difference, Users should do fully test, data in this table is from single module apply in municipal sewage plant and under the conditions of 25 °C and - 10KPa TMP.

Table 2.2 Double deck module specifications *

Module Type	Single membrane area (m ²)	Number of membrane elements (pc)	Effective membrane area (m ²)	Capacity [#] (m ³ /d)	Aeration volume (m ³ /min)	Size (mm)			Weight (Kg)	Membrane case weight (Kg)	Diffuser case weight (Kg)
						L	W	H			
SINAP80-100D	0.8	200	160	64-96	1.4-1.6	1660	910	3280	840	780	60
SINAP80-200D		400	320	128-192	2.8-3.2	3100			1690	1580	110
SINAP100-100D	1.0	200	200	80-120	1.4-1.6	1660	910	3780	1075	1015	60
SINAP100-200D		400	400	160-240	2.8-3.2	3100			2020	1910	110
SINAP150-100D	1.5	200	300	120-180	1.4-1.6	1660	910	4780	1740	1680	60
SINAP150-200D		400	600	240-360	2.8-3.2	3100			3020	2910	110

* The data of membrane module listed above are for design reference only, actual size in kind prevail.

For different water quality the productivity will have a big difference, Users should do fully test, data in this table is from single module apply in municipal sewage plant and under the conditions of 25 °C and - 10KPa TMP.

Table 2.3 Membrane module specifications

Material	Membrane elements	PVDF membrane + PET support layer + ABS panel
	Manifold, diffuser	ABS
	Guide panel	PVC
	Frame and standard metal parts	SUS304
Fix method	Membrane module	① Connect with the embedded parts; ② Fixed with expansion bolt (according to the situation in site)
Application condition	Water temperature (°C)	5~40
	pH	6~9
	Influent SS (mg/L)	< 9000
	MLSS (mg/L)	3000~15000
	Minimum effective depth of membrane tank (mm)	Membrane module height + (300~500)
	Max TMP (kPa)	-25
	Operate TMP (kPa)	0~-25
	Aeration volume (L/min·pc)	Single deck: 10~12
Double deck: 7~8		
Permeate water quality	SS (mg/L)	≤3
	NTU	≤3

3. MBR process description

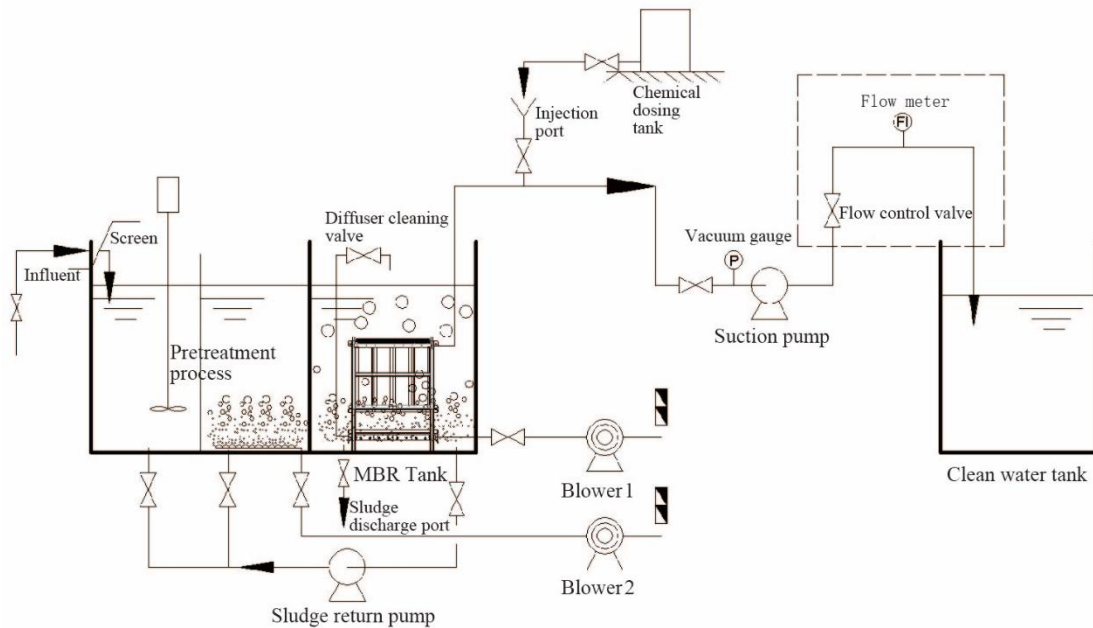

Figure 3-1 MBR Process description

Basic MBR Process description shown in figure 3-1:

(1) Screen

Filter large suspended or floating solid.

(2) Pretreatment process

Treat raw water to meet the MBR influent require. It's also the important process to meet the final effluent quality.

(3) MBR tank (Aerobic pool)

Usually when treating small amount sewage, MBR tank is aerobic tank; when treating large amount sewage, use MBR tank and aerobic tank split design. Membrane module install in MBR tank, use suction pump to collect permeate water. The MBR tank can realize simultaneous degradation of organic and separation of muddy in water.

(4) Miscible liquids backflow

Set sludge return pipe at bottom of MBR tank, return the sludge to front treat process by sludge return pump. MBR is a continuous operation system, to achieve the removal of COD, NH₃-N, TN and TP in water.

4. SINAP MBR system design process

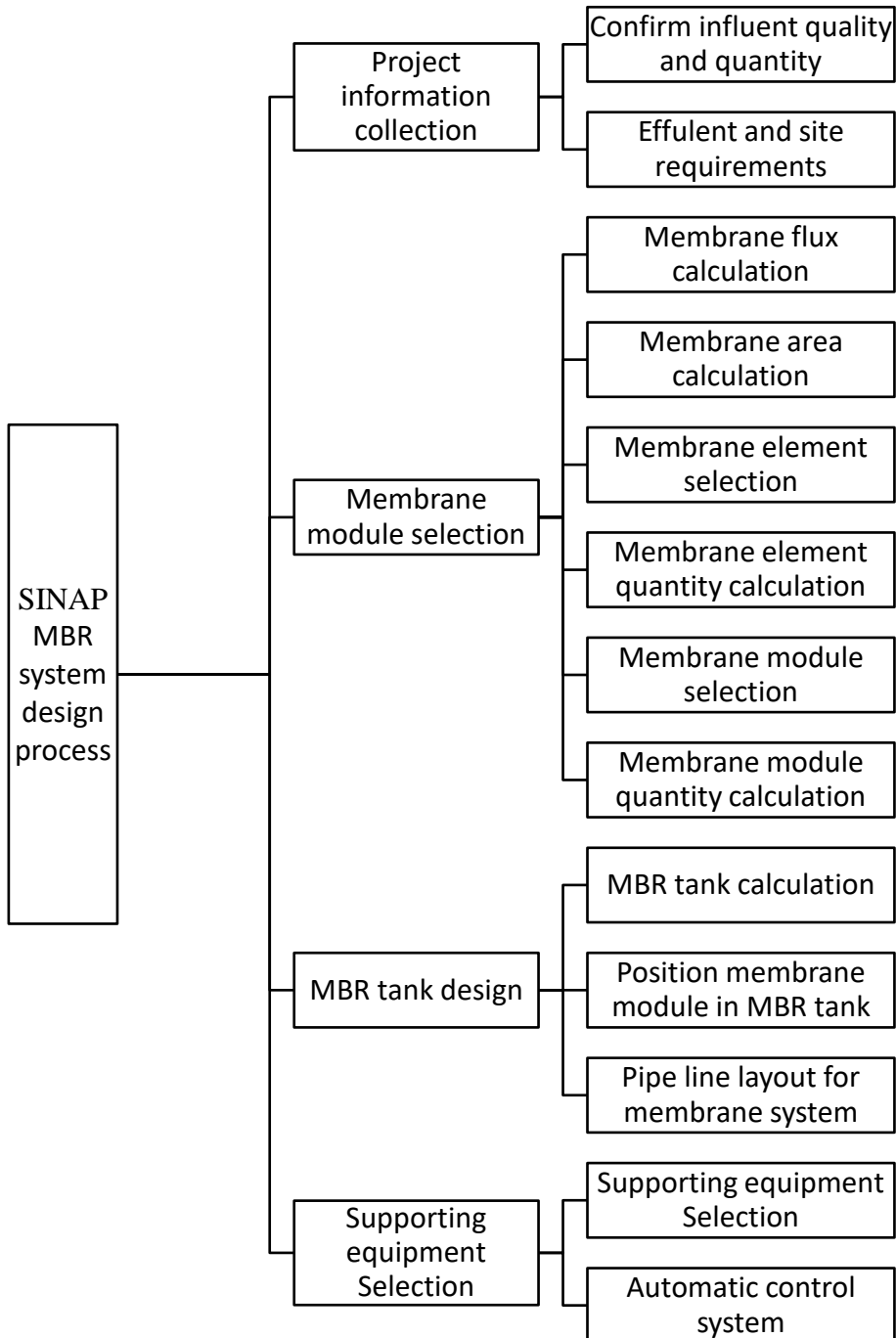

5. SINAP MBR system design

5.1 Confirm influential quality and quantity

Collect design data of MBR project including water quantity, water quality, whether there is MBR tank etc. The information requirements shown in Table 5.1.

Table 5.1 MBR system information requirements (**By user**)

Types of sewage	<input type="checkbox"/> Domestic wastewater	<input type="checkbox"/> Industrial wastewater (Description: Type of industrial sewage)
Capacity	<input type="checkbox"/> Design flux: m ³ /d	<input type="checkbox"/> Capacity: m ³ /d
MBR tank size	<input type="checkbox"/> Yes (Length*width* height) Effective depth: m	<input type="checkbox"/> No (Provide information about site restrictions and special landforms for design reference)
Oil contents	<input type="checkbox"/> Yes (Oil content: mg/L)	<input type="checkbox"/> No
Hardness (Ca²⁺ and Mg²⁺)	<input type="checkbox"/> Yes (Content: mg/L)	<input type="checkbox"/> No

5.1.1 Influent requirements for MBR system

MBR is similar to the traditional activated sludge method on remove biodegradable organic. However, due to the membrane, the requirement for influent is different from traditional activated sludge method. The following two points should be considered:

- (1) Whether the influent contains organic substances which are harmful to the membrane and its degradability;
- (2) The influent shall be thoroughly analyzed and be fully verified through tests.

The following are standard requirements for the influent of MBR system (see Table 5.2).

Table 5.2 Requirements for the influent of MBR system

Items	Tempera ture (°C)	COD (mg/L)	BOD (mg/L)	SS (mg/L)	Oil(mg/L)		NH4-N (mg/L)
					Animal and plant oil	Mineral oil	
Requirement	5-40	<500	<300	<150	<30	<3	<50

For water not meet the requirement above pretreatment should be procced.

Requirements for the pretreatment of MBR system as follows:

- (1) Requirement for solid and particles

MBR influent must pass screen less than 3mm, if not pretreated, the larger solid particles may cause scratches on the membrane surface.

(2) Requirement for pH

Influent pH needs in range 6~9.

(3) Requirement for Hardness

If influent has high hardness, calcium salt, magnesium salt and other precipitated materials will form inorganic layer on the membrane surface, seriously harm to the membrane and whole system, calcium and magnesium ion concentration needs < 100mg/L.

(4) Requirement for temperature

Normally influent for MBR require lower than 40°C, higher temperature will affect to biochemical process and membrane life. However, in some high-temperature biochemical treatment systems, the limit can be relaxed to 45°C.

(5) Requirement for oil

Normally membrane cannot treat water contains oil, oil will attach on the membrane surface lower the flux. Generally, oil resistance of the membrane is less than 30mg/L, in which the mineral oil content is less than 3mg/L. Specific situation shall be determined by test.

(6) Requirement for organic solvent

General, membrane elements cannot treat wastewater containing organic solvents, a certain concentration of organic solvents will erode the membrane filtration layer. (For special cases, full test verification is required).

(7) Requirement for chemical contaminants

The influent should not contain polymeric flocculant, epoxy resin coating and the soluble substance of ion-exchange resin, which will form chemical pollution on the membrane surface and reduce the flux.

5.1.2 Others

(1) If raw water contains surfactant or refractory organic matter (such as landfill leachate, etc.) or the temperature is low all year long, the designed membrane flux needs lower than standard flux.

- (2) When other aeration system set up in the membrane tank shall not disturb the aeration of membrane module.
- (3) Single membrane tank normally limited 18 sets of membrane modules. If use large quantity of membrane module, it shall be design divided into several membrane tank with the same number of membrane modules in each tank to facilitate the maintenance and management.
- (4) The MBR needs to use a separate blower. If used combine with other equipment, the air pressure and aeration uniformity of the membrane tank shall be considered.

5.2 Membrane flux formulation

It will aggravate membrane fouling when the membrane system is running higher than the critical flux and make TMP increases rapidly. In order to maintain a long-term stable membrane system, an appropriate membrane flux should be selected. [Membrane flux refers to the amount of fluid passing through a unit area in unit time, generally expressed as $m^3/(m^2 \cdot d)$]

Table 5.3 Membrane design flux reference

Types of water	Membrane design flux $J_0: m^3/(m^2 \cdot d)$	Remark
Domestic sewage	0.4~0.6 (average)	The optimum membrane flux should be determined by test
Industrial wastewater	0.2~0.4 (average)	

Note: The design flux above is the actual daily flux, for reference only;
Designers should fully consider the situation on site and the reliability of operation.

5.3 Membrane area calculation

To calculate membrane area according to water quality, water quantity and design flux.

Membrane area calculation formula:

$$A_{\text{Theory}}(m^2) = \frac{Q}{J_0} \quad (5-1)$$

Explain: A_{Theory} : Theoretical membrane area (m^2)

Q: Capacity (m^3/d)

J_0 : Design flux [$m^3/(m^2 \cdot d)$] (see table 5.3)

5.4 Membrane element selection

Membrane element selection should according factors like effective water level etc.

Table 5.4 Membrane element selection reference

Membrane series	Single deck module			Double deck module		
	SINAP80	SINAP100	SINAP150	SINAP80	SINAP100	SINAP150
Effective area S_0 (m^2)	0.8	1.0	1.5	0.8	1.0	1.5
Effective depth of membrane tank (h) (mm)						
2200	√	×	×	×	×	×
2500	√	√	×	×	×	×
3000	√	√	√	×	×	×
3500	√	√	√	√	×	×

4000	√	√	√	√	√	×
5000	√	√	√	√	√	√

Mark: In table 5.4 “√” means this membrane element series can be selected under this effective depth, “×” means cannot use

5.5 Membrane elements calculation

According to calculated total membrane area requirement and selected membrane element. **To calculating membrane elements using quantity by the following formula.**

Formula for calculating membrane elements using quantity in theory:

$$N_{e \text{ Theory}} (\text{piece}) = \frac{A_{\text{Theory}}}{S_0} \quad (5-2)$$

Explain: $N_{e \text{ Theory}}$: Membrane elements using quantity in theory (piece)

A_{Theory} : Theoretical membrane area (m²)

S_0 : Single membrane element effective area (m²)

5.6 Membrane Module calculation

Refer to the different membrane models provided in Table 5.5, select “X”, and calculate the theoretical membrane module using quantity according to the following formula.

$$N_{m \text{ Theory}} (\text{set}) = \frac{N_{e \text{ Theory}}}{X} \quad (5-3)$$

Explain: $N_{m \text{ Theory}}$: Membrane modules using quantity in theory (set)

$N_{e \text{ Theory}}$: Membrane elements using quantity in theory (piece)

X : Selected membrane elements quantity in single membrane module (piece) (see table 5.5)

According to the water quality, the $N_{m \text{ Theory}}$ of membrane elements using quantity in theory needs increased or decreased (integrated) to obtain the actual number of membrane modules $N_{m \text{ Practice}}$ to meet the requirements of water production;

$$N_{m \text{ Practice}} \approx N_{m \text{ Theory}} \quad (5-4)$$

(1) The actual membrane elements using quantity calculation:

$$N_{e \text{ Practice}} = N_{m \text{ Practice}} \times X \quad (5-5)$$

Explain: $N_{e \text{ Practice}}$: Actual membrane elements using quantity (piece)

$N_{m \text{ Practice}}$: Actual membrane modules using quantity (set)

X : Membrane elements quantity in single membrane module (piece)

(2) The actual membrane area using quantity calculation:

$$A_{\text{Practice}} = N_{e \text{ Practice}} \times S_0 \quad (5-6)$$

Explain: A_{Practice} : Actual membrane area (m²)

$N_{e \text{ Practice}}$: Actual membrane elements using quantity (piece)

S_0 : Single membrane element effective area (m^2)

(2) Actual membrane flux calculation:

$$J_{\text{Practice}} = \frac{Q}{A_{\text{Practice}}} \quad (5-7)$$

Explain: Q: Capacity (m^3/d)

A_{Practice} : Actual membrane area (m^2)

J_{Practice} : Actual membrane flux [$m^3/(m^2 \cdot d)$]

Table 5.5 Table of membrane elements quantity contained in membrane module (For reference)

Membrane module type	Membrane quantity X (piece)	Membrane module type	Membrane quantity X (piece)	Membrane module type	Membrane quantity X (piece)
SINAP80-60	60	SINAP100-60	60	SINAP150-100	100
SINAP80-80	80	SINAP100-80	80	SINAP150-120	120
SINAP80-100	100	SINAP100-100	100	SINAP150-160	160
SINAP80-120	120	SINAP100-120	120	SINAP150-200	200
SINAP80-160	160	SINAP100-160	160	SINAP150-100D	200
SINAP80-200	200	SINAP100-200	200	SINAP150-200D	400
SINAP80-100D	200	SINAP100-100D	200		
SINAP80-200D	400	SINAP100-200D	400		

Mark: In one project should select same membrane module type.

5.7 Membrane tank size calculation

Choose same membrane module type then uniformly arranged in a single or multiple membrane tank. Membrane module size show in table 5.6

Table 5.6 Membrane module size

Membrane case type	Membrane module type	Size (mm)			
		L	W	H	
Single deck	SINAP80-60	1090	760	1900	
	SINAP80-80	1380			
	SINAP80-100	1660			
	SINAP80-120	1940			
	SINAP80-160	2540			
	SINAP80-200	3110			
	SINAP100-60	1090	760	2150	
	SINAP100-80	1380			
	SINAP100-100	1660			
	SINAP100-120	1940			
	SINAP100-160	2540			
	SINAP100-200	3110			
		SINAP150-100	1660	760	2650
		SINAP150-120	1940		
SINAP150-160		2540			
SINAP150-200		3110			
Double deck	SINAP80-100D	1660	910	3250	
	SINAP80-200D	3110			

Single membrane tank size calculation:

Membrane tank length L_p :

$$L_p = (N_{m \text{ Practice}} - 1) \times A + 2000 \tag{5-8}$$

Explain: L_p : Length of membrane tank (mm)

$N_{m \text{ Practice}}$: Actual membrane modules using quantity (set)

A: Center distance between membrane modules (value: 1100~1300mm,

show in figure 5-1)

Membrane tank width W_p :

$$W_p = L + 1000 \tag{5-9}$$

Explain: W_p : Width of membrane tank (mm)

L: Length of membrane module (mm) (details show in table 5.6)

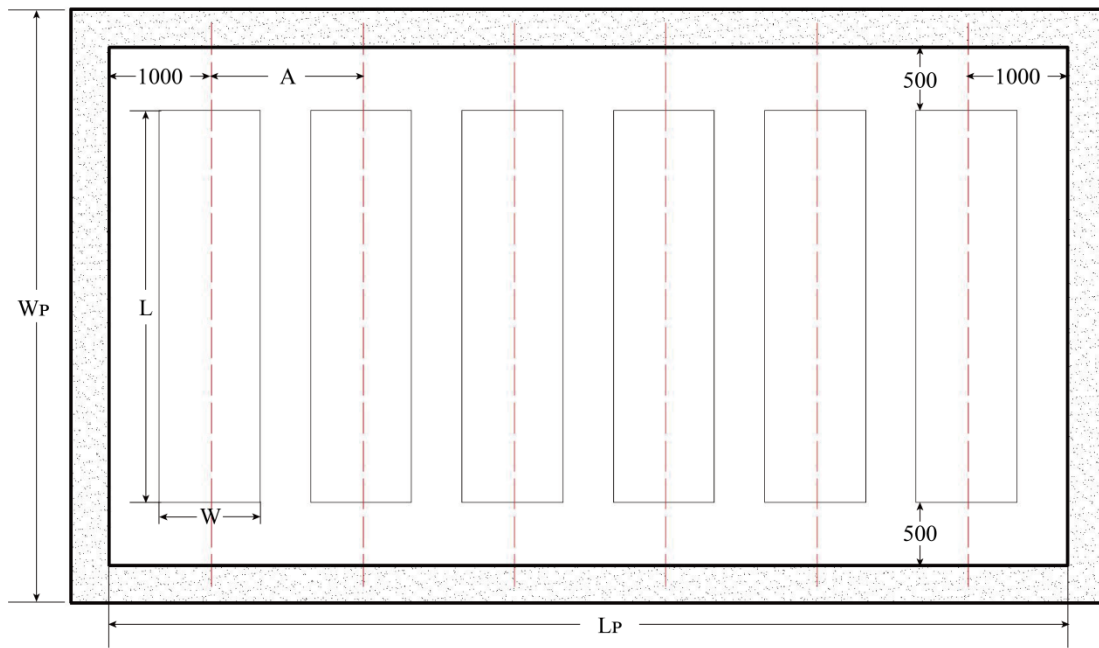

L: Length of membrane module
 W: Width of membrane module
 LP: Length of membrane tank
 WP: Width of membrane tank
 A: Center distance between membrane modules

Figure 5-1 Membrane module layout (unit: mm)

Membrane tank height $H_{\text{membrane tank}}$:

$$H_p = H + h_1 + h_0 \quad (5-10)$$

Explain: H: Height of membrane module (mm) (show in table 5.6);

h_1 : Protective height of membrane module (value: 300~500mm, show in figure 5-2);

h_0 : Over height (value: 500~1000mm, show in figure 5-2);

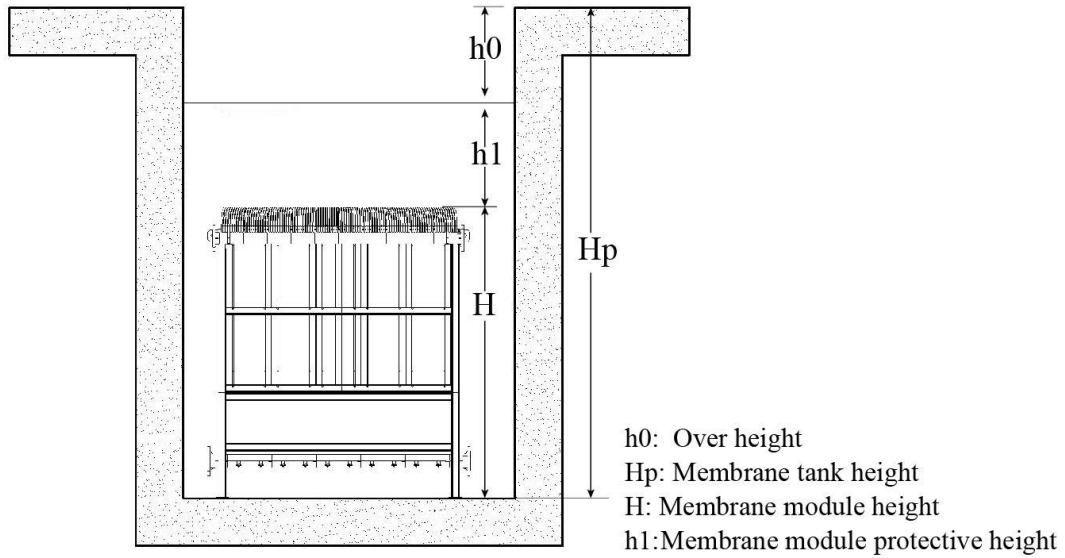

Figure 5-2 Membrane tank height schematic (unit: mm)

5.8 Membrane system support equipment selection

5.8.1 MBR blower

(1) Air volume:

$$Q_{Air} = N_{e \text{ Practice}} \times q \times K_1 \div 1000 \quad (5-11)$$

Explain: Q Air: Air volume for MBR system (m3/min);

$N_{e \text{ Practice}}$: Actual membrane elements using quantity (piece);

q: Air volume of single membrane element [L/(min·pc)], show in table 5.7;

K1: Safety factor, Value: 1.1~1.2;

Table 5.7 Air volume for single membrane element

Membrane case type	Membrane element series	Air volume q [L/(min·pc)]	
		Standard volume	Volume limited
Single deck module	SINAP150	10~12	15
	SINAP100		
	SINAP80		
Double deck module	SINAP150	7~8	10
	SINAP100		
	SINAP80		

(2) Air pressure:

$$P_{Air} \geq 1 \times 10^3 \times 9.8 \times (h+1) \div 1000 \quad (5-12)$$

Explain: P_{Air} : Air pressure for membrane system (kPa)

h: Effective water depth (m)

1×10^3 : unit kg/m³

9.8: Each 1kg object receive 9.8N gravity, unit N/kg

Mark: The result calculated by this formula is the minimum needs for membrane system. The actual air pressure needs to consider supporting equipment and pipe installation.

5.8.2 MBR suction pump

(1) Capacity:

The relevant technical parameters of membrane suction pump can be calculated according to the daily capacity of application and operation pattern. The recommended operation pattern is 8 minutes operate and 2 minutes rest (adjustable under special condition). As an example, the flow of the membrane suction pump can be calculated as follows:

$$Q_{Capacity} \geq \frac{Q_{Daily}}{24 \times \frac{8}{8+2}} \times K_2 \quad (5-13)$$

Explain: $Q_{Capacity}$: Capacity of membrane suction pump (m³/h)

Q_{Daily} : Daily capacity of application (m³/d)

K_2 : Safety factor, Value: 1.1~1.2

(3) Suction of pump:

For overcome TMP, losing in piping line and different water level (difference from water level of membrane tank to pump or top of pipe) suction of suction pump choose 4~6m.

5.8.3 Chemical cleaning on site dosing quantity calculation

Chemical cleaning is an important way to keep membrane in good condition, to keep membrane flux and extend membrane life.

Membrane module dosing quantity calculation formula:

$$V_{Dosing} = N_{m\ Practice} * X * V_0 \div 1000 \quad (5-14)$$

Explain: V_{Dosing} : Chemical cleaning dosing quantity (m³)

$N_{m\ Practice}$: Actual membrane modules using quantity (set)

X: Membrane elements quantity in single membrane module (piece)

V₀: Single membrane element dosing quantity (L/PC) (show in table 5.8)

Table 5.8 Single membrane element dosing quantity *

Membrane element series	Dosing quantity V ₀ (L/片)
SINAP80	3.0
SINAP100	3.5
SINAP150	5.0

*Mark: The cleaning agent is a diluted solution of a certain concentration, not the original solution purchased on the market.

5.9 Membrane system design reference

Reference: Capacity $Q=3000\text{m}^3/\text{d}$; BOD=250mg/L (Only consider BOD removal of organic)

Design parameters		Sewage type	Municipal/domestic sewage	Industrial/special wastewater	Remark	
Membrane standard design flux $J_0(\text{m}^3/\text{m}^2 \cdot \text{d})$			0.4~0.6	0.2~0.4		
Membrane design flux in this reference $J_0(\text{m}^3/\text{m}^2 \cdot \text{d})$			0.5	0.3		
		$A_{\text{Theory}} (\text{m}^2)$	$A_{\text{Theory}}=3000 \div 0.5=6000 (\text{m}^2)$	$A_{\text{Theory}}=3000 \div 0.3=10000 (\text{m}^2)$	See chapter 5.3 formula 5-1	
		$N_{\text{e Theory}} (\text{piece})$ SINAP150 $S_0=1.5\text{m}^2$	$N_{\text{e Theory}}=6000 \div 1.5=4000 (\text{piece})$	$N_{\text{e Theory}}=10000 \div 1.5=6667 (\text{piece})$	See chapter 5.5 formula 5-2	
Single deck module	Membrane module selection	SINAP150-200 X=200	$N_{\text{m Theory}}=4000 \div 200=20 (\text{set})$ $N_{\text{m Practice}}=N_{\text{m Theory}}=20 (\text{set})$ $A_{\text{e Practice}}=20 \times 200 \times 1.5=6000 (\text{m}^2)$ $J_{\text{Practice}}=3000 \div 6000=0.5 (\text{m}^3/\text{m}^2 \cdot \text{d})$	$N_{\text{m Theory}}=6667 \div 200=33.3 (\text{set})$ $N_{\text{m Practice}} \approx N_{\text{m Theory}}=34 (\text{set})$ $A_{\text{e Practice}}=34 \times 200 \times 1.5=10200 (\text{m}^2)$ $J_{\text{Practice}}=3000 \div 10200=0.294 (\text{m}^3/\text{m}^2 \cdot \text{d})$	See chapter 5.6 formula 5-3,5-4,5-5,5-6,5-7	
	Single membrane tank size (mm)	Totally 2 membrane tanks	$L_p=(10-1) \times 1200+2000=12800(\text{mm})$	$L_p=(17-1) \times 1200+2000=21200(\text{mm})$	See chapter 5.7 formula 5-8,5-9、5-10	
			$W_p=3106+1000=4106(\text{mm})$			
			$H_p=2650+500+500=3650(\text{mm})$			
	MBR blower			$Q_{\text{Air}}=4000 \times 10 \times 1.1 \div 1000=44(\text{m}^3/\text{min})$ $P_{\text{Air}} \geq 1 \times 10^3 \times 9.8 \times (h+1) \div 1000$	$Q_{\text{Air}}=6800 \times 10 \times 1.1 \div 1000=74.8(\text{m}^3/\text{min})$ $P_{\text{Air}} \geq 1 \times 10^3 \times 9.8 \times (h+1) \div 1000$	See chapter 5.8 formula 5-11,5-12
	Suction pump (8 minutes operate and 2 minutes rest)			$Q_{\text{Capacity}}=3000 \div 24 \div 0.8 \times 1.1 \approx 172(\text{m}^3/\text{h})$, Suction 4~6m		See chapter 5.8 formula 5-13
Chemical cleaning dosing quantity			$V_{\text{Dosing}}=20 \times 200 \times 5.0 \div 1000=20 \text{ m}^3$	$V_{\text{Dosing}}=34 \times 200 \times 5.0 \div 1000=34 \text{ m}^3$	See chapter 5.8 formula 5-14	

	Vacuum manometer range (recommendation)		-0.1~0.1Mpa		
Double deck module	Membrane module selection	SINAP150-200D X=400	$N_{m \text{ Theory}}=4000 \div 400=10$ (set) $N_{m \text{ Practice}}=N_{m \text{ Theory}}=10$ (set) $A_{\text{Practice}}=10 \times 400 \times 1.5=6000$ (m2) $J_{\text{Practice}}=3000 \div 6000=0.5$ (m ³ /m ² ·d)	$N_{m \text{ Theory}}=6667 \div 400=16.67$ (set) $N_{m \text{ Practice}} \approx N_{m \text{ Theory}}=17$ (set) $N_{e \text{ Practice}}=17 \times 400 \times 1.5=10200$ (m2) $J_{\text{Practice}}=3000 \div 10200=0.294$ (m ³ /m ² ·d)	See chapter 5.6 formula 5-3,5-4,5-5,5-6,5-7
	Single membrane tank size (mm)	Totally 1 membrane tank	$L_p=(10-1) \times 1200+2000=12800$ (mm)	$L_p=(17-1) \times 1200+2000=21200$ (mm)	See chapter 5.7 formula 5-8,5-9、5-10
			$W_p=3106+1000=4106$ (mm)		
			$H_p=4780+500+500=5780$ (mm)		
	MBR blower		$Q_{\text{Air}}=4000 \times 7 \times 1.1 \div 1000=30.8$ (m ³ /min) $P_{\text{Air}} \geq 1 \times 10^3 \times 9.8 \times (h+1)$	$Q_{\text{Air}}=6800 \times 7 \times 1.1 \div 1000=52.36$ (m ³ /min) $P_{\text{Air}} \geq 1 \times 10^3 \times 9.8 \times (h+1)$	See chapter 5.8 formula 5-11,5-12
	Suction pump (8 minutes operate and 2 minutes rest)		$Q_{\text{Capacity}}=3000 \div 24 \div 0.8 \times 1.1 \approx 172$ (m ³ /h), Suction 4~6m		See chapter 5.8 formula 5-13
	Chemical cleaning dosing quantity		$V_{\text{Dosing}}=10 \times 400 \times 5.0 \div 1000=20$ (m ³)	$V_{\text{Dosing}}=17 \times 400 \times 5.0 \div 1000=34$ (m ³)	See chapter 5.8 formula 5-14
	Vacuum manometer range (recommendation)		-0.1~0.1MPa		

5.10 Membrane tank layout

(1) Choose same membrane module type in one application. Also arrange same membrane module type and same quantity in single or multiple membrane tank;

(2) When use large number of membrane modules, multiple membrane tanks should be set, and the number of membrane modules in each membrane tank should not over 18 sets.

Correct and incorrect layout of multiple membrane tanks show in figure 5-3 and 5-4.

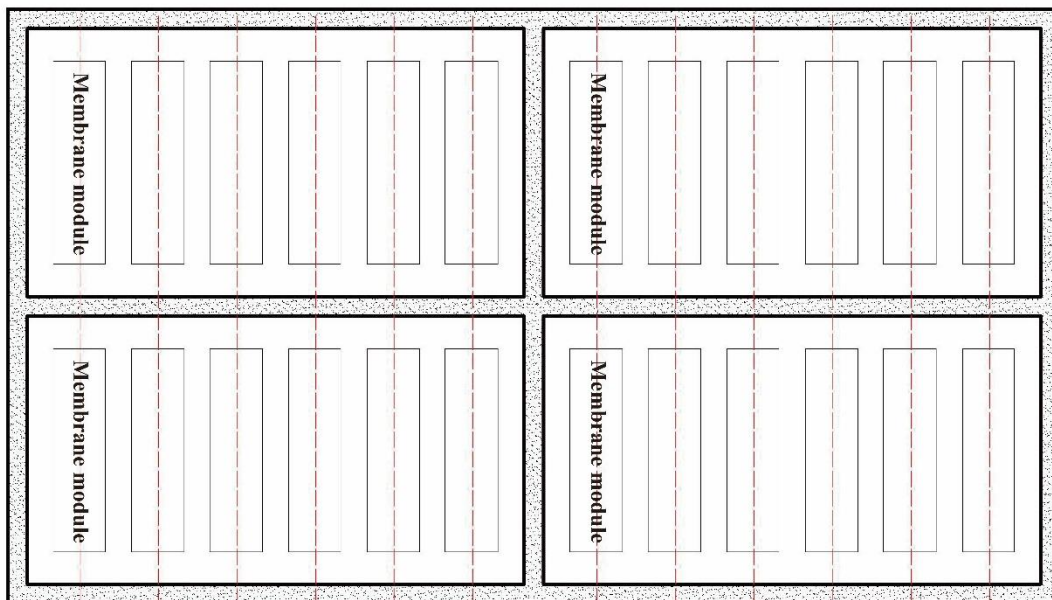

Figure 5-3 Correct layout of multiple membrane tanks

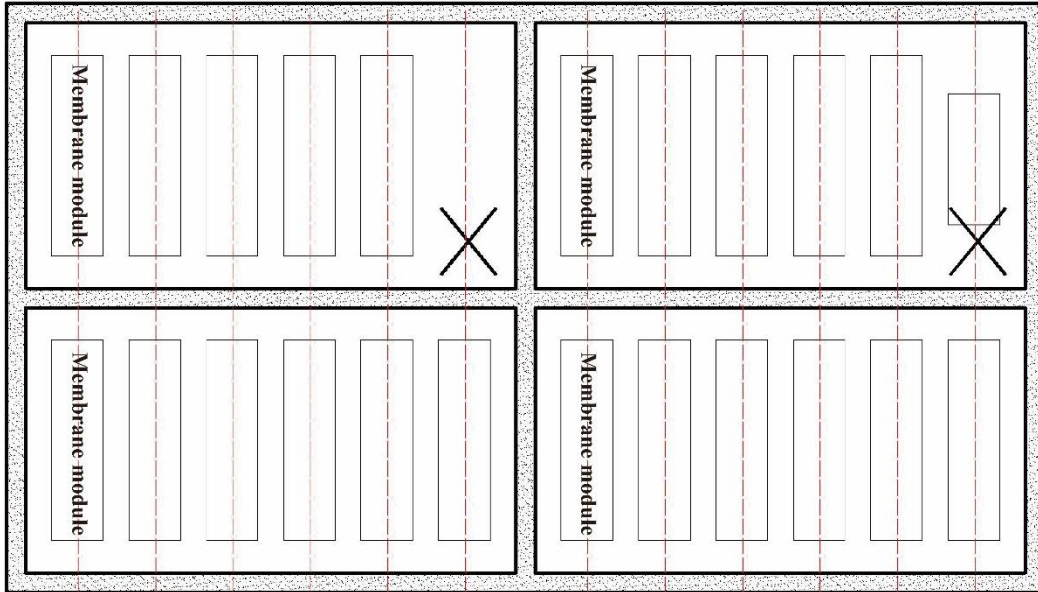

Figure 5-4 Incorrect layout of multiple membrane tanks

5.11 Water level and height of membrane tank

When membrane system in operating, it should have at least 300mm (500mm recommended) protective height of membrane module (Show in figure 5-5).

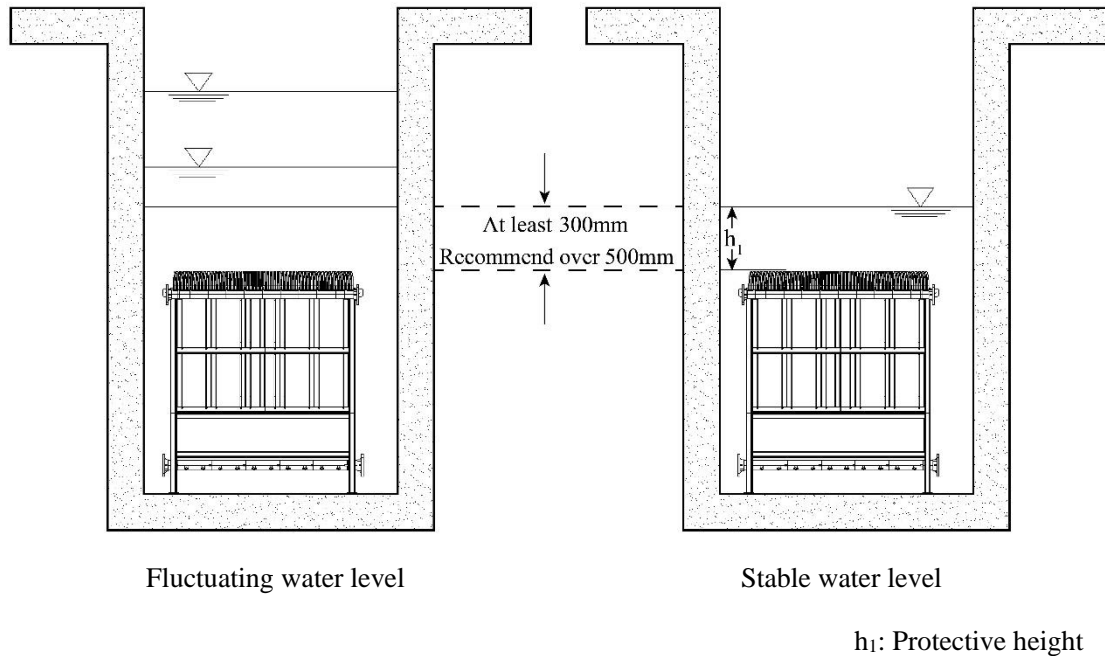
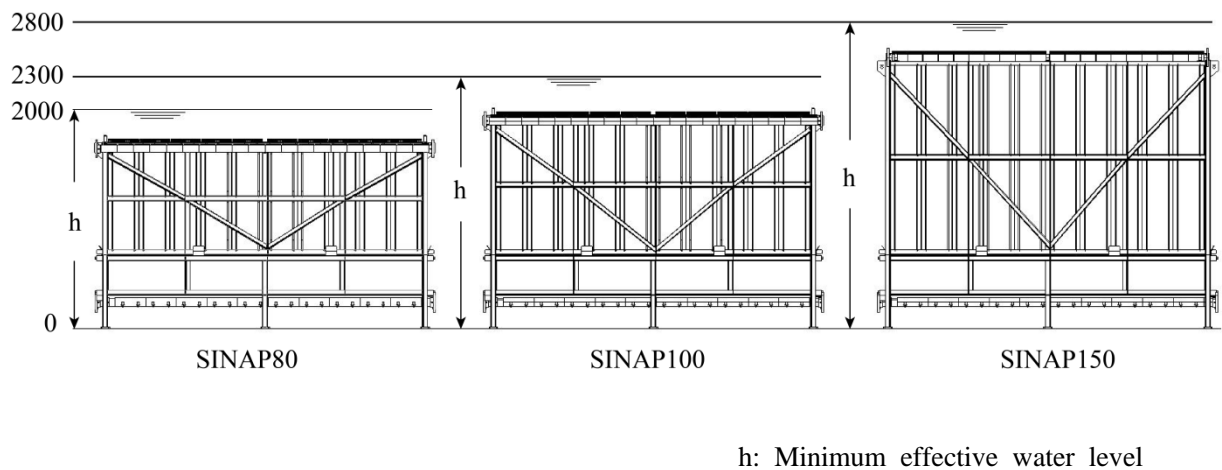

Figure 5-5 Protective height of membrane module (unit: mm)

Users can calculate effective water level according to membrane module selected.

Figure 5-6 show effective water level of different membrane series.



(a) Single deck membrane module

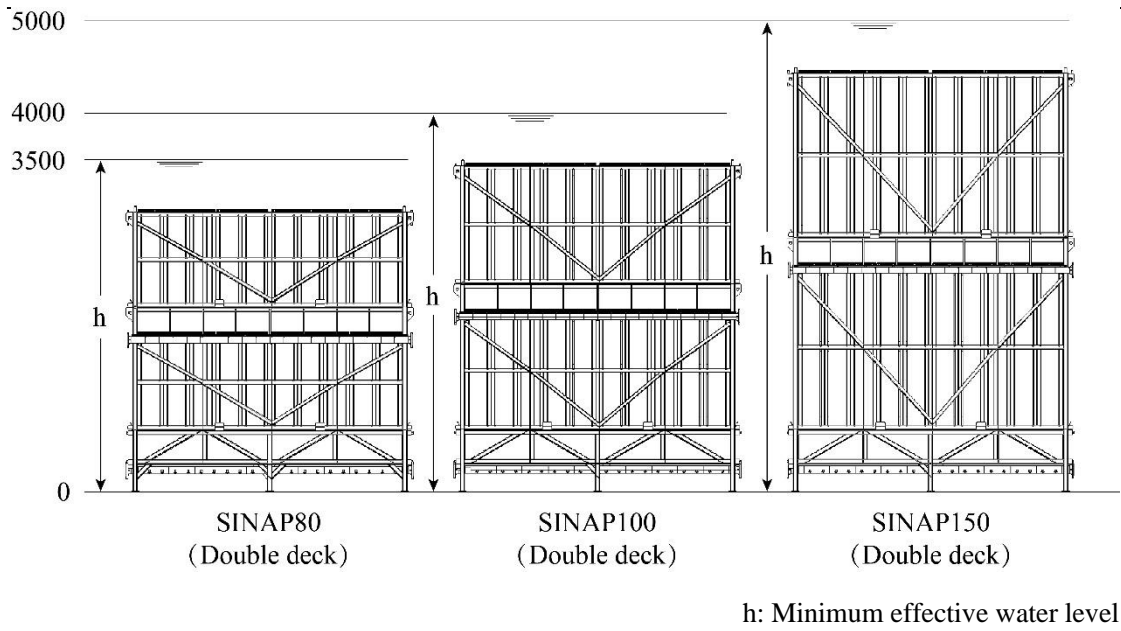

(b) Double deck membrane module

Figure 5-6 Minimum effective water level of membrane tank (unit: mm)

Minimum height of membrane tank is minimum effective water level plus 500~1000mm (Over height), show in figure 5-7.

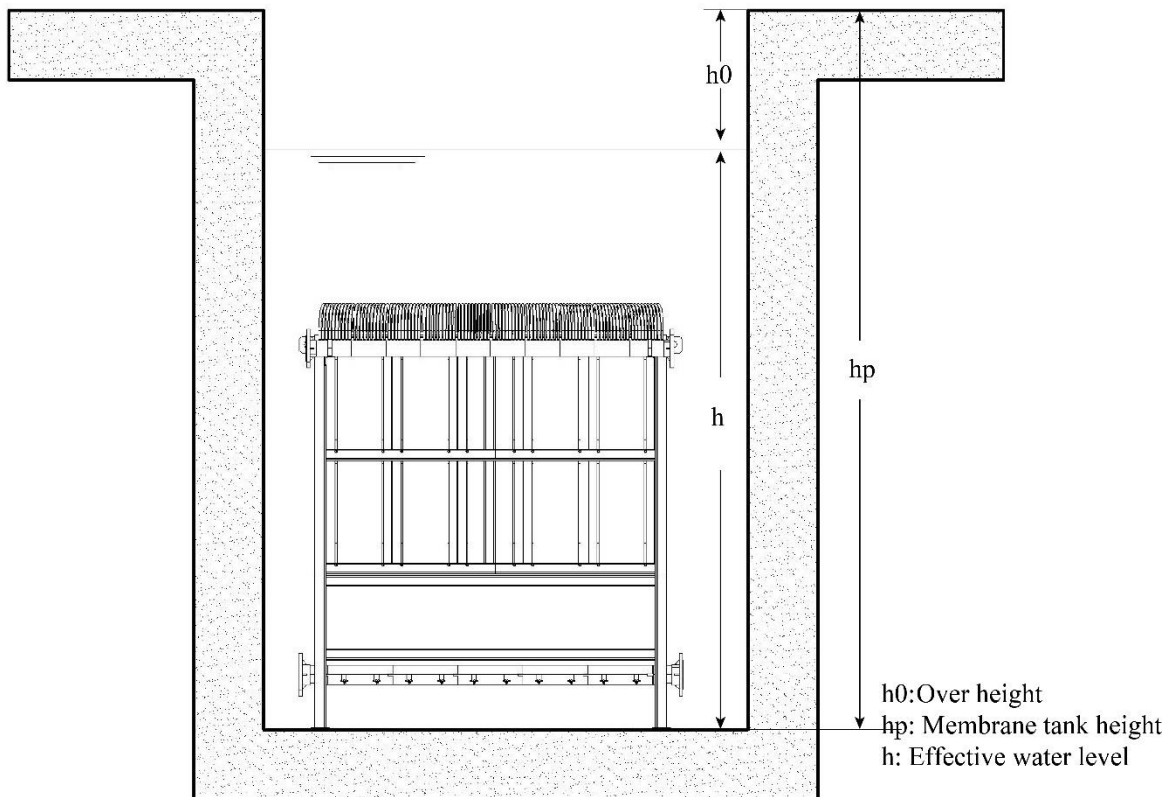

Figure 5-7 Minimum height of membrane tank

5.12 Membrane module position

Membrane module position sequence: Diffuser case → membrane case

5.12.1 Diffuser case position

Notice! Diffuser case must fix to the bottom of the membrane tank.

Notice! The diffuser must be adjusted to a horizontal state.

(1) To fix membrane module by weld the anchor bolts with embedded parts after position. There are two method to set embedded parts show as 5-8(a)、(b); Recommended embedded parts size: 200mm×200mm×10mm.

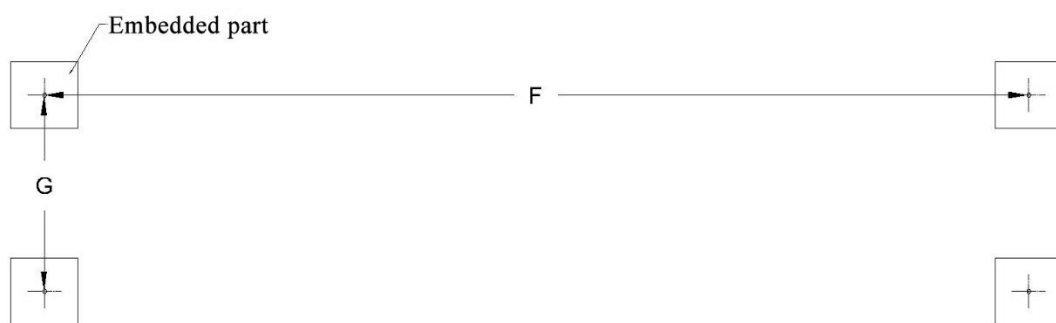

Mark: G and F see table 7.1/7.2

(a) Method one

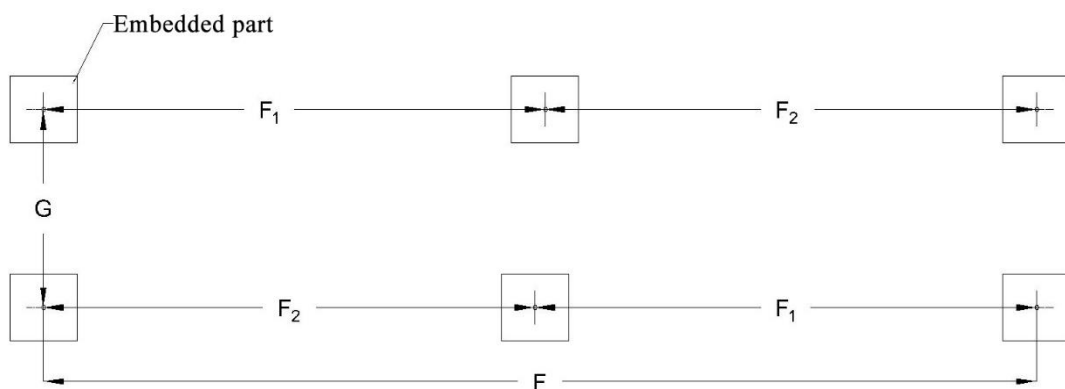

Mark: G, F, F1 and F2 see table 7.1/7.2

(b) Method two

Figure 5-8 Embedded parts position

(2) Use expansion anchor bolts to fix diffuser case at the bottom of membrane tank.

5.12.2 Membrane case position

(1) Method one: use bolts (show in figure 5-9)。

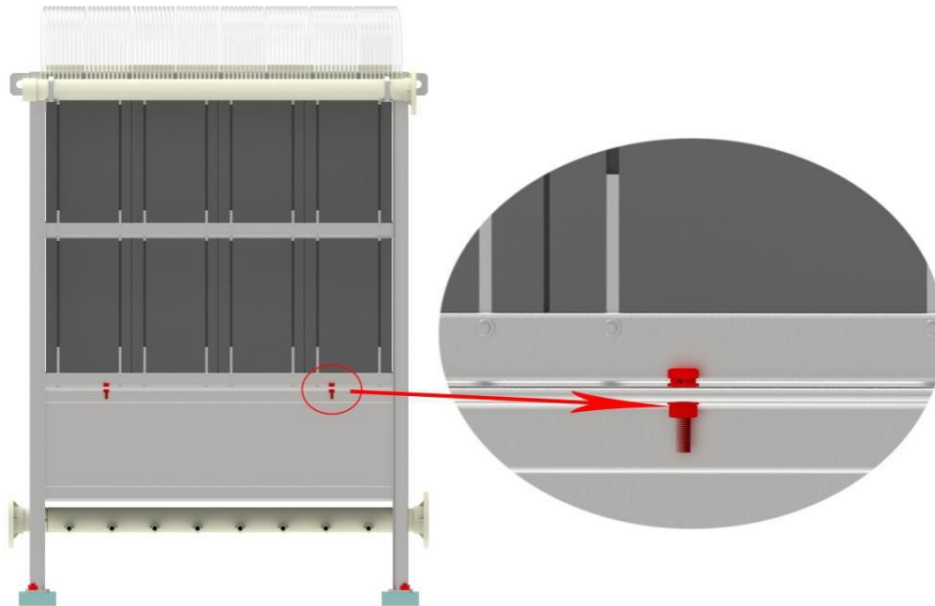

Figure 5-9 Membrane case position method one

(2) Method two: guide rail fix (Show in figure 5-10)

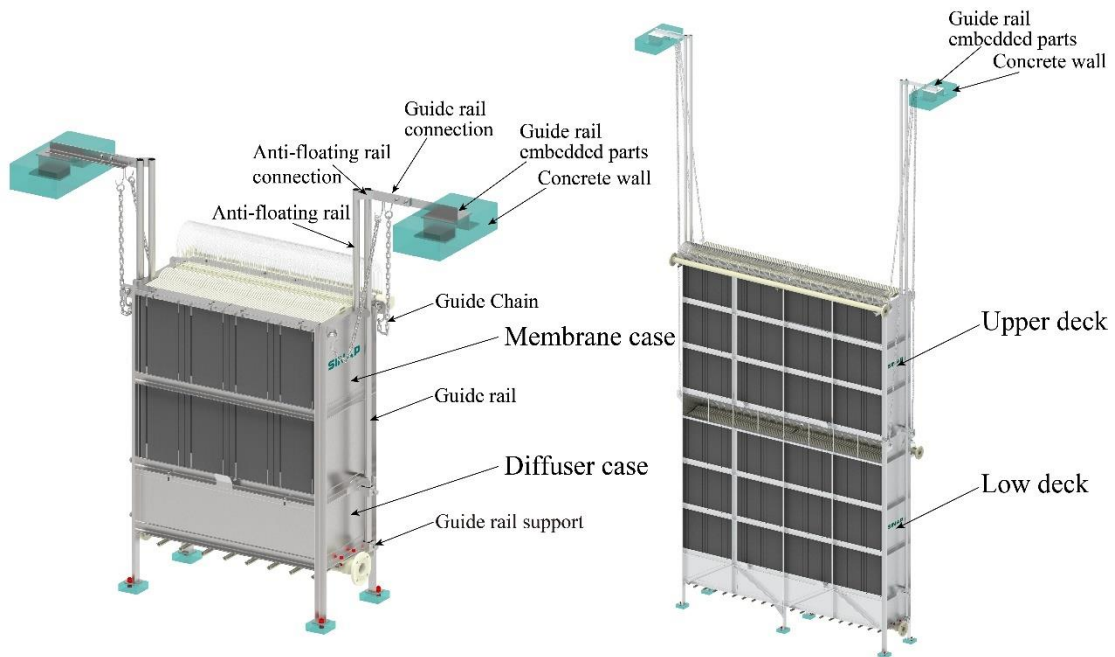
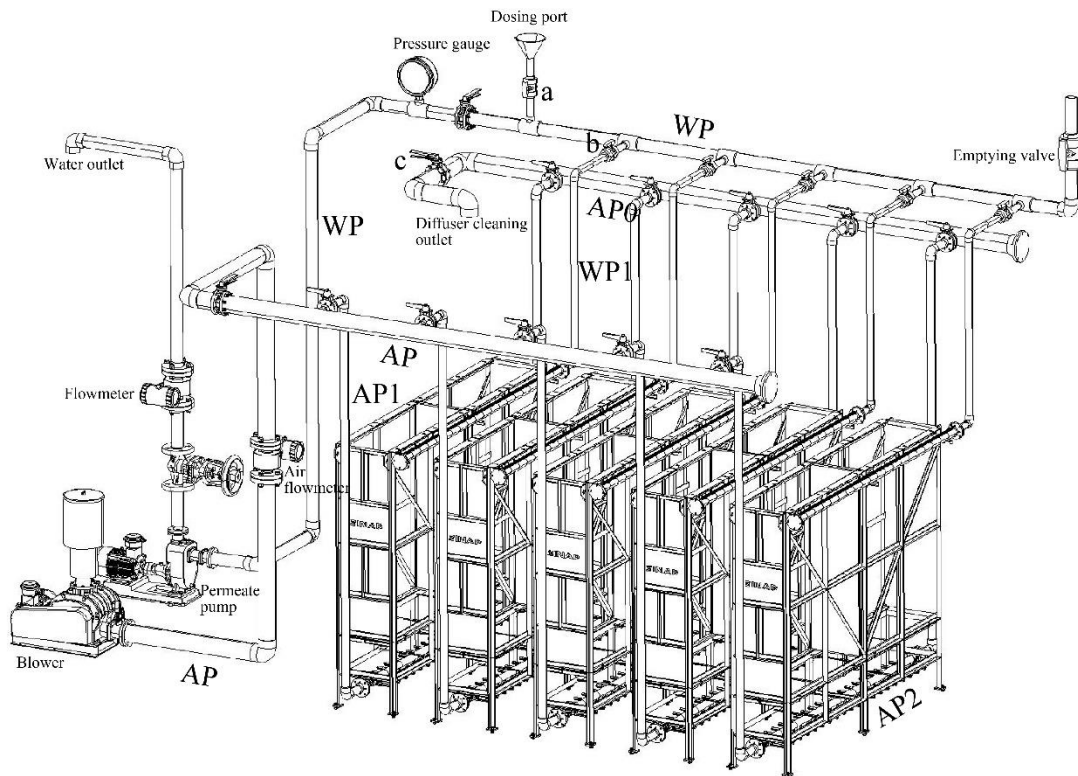

Figure 5-10 Membrane case position method two

Notice! If choose guide rail method, users need to set guide rail embedded parts in the wall or top of the tank. (details please counsel SINAP)

5.13 Membrane system pipeline design

Pipeline connection of membrane modules show in figure 5-11(a)、(b)。



(a) Membrane system pipeline connection method one (main pipe cleaning chemical dosing)

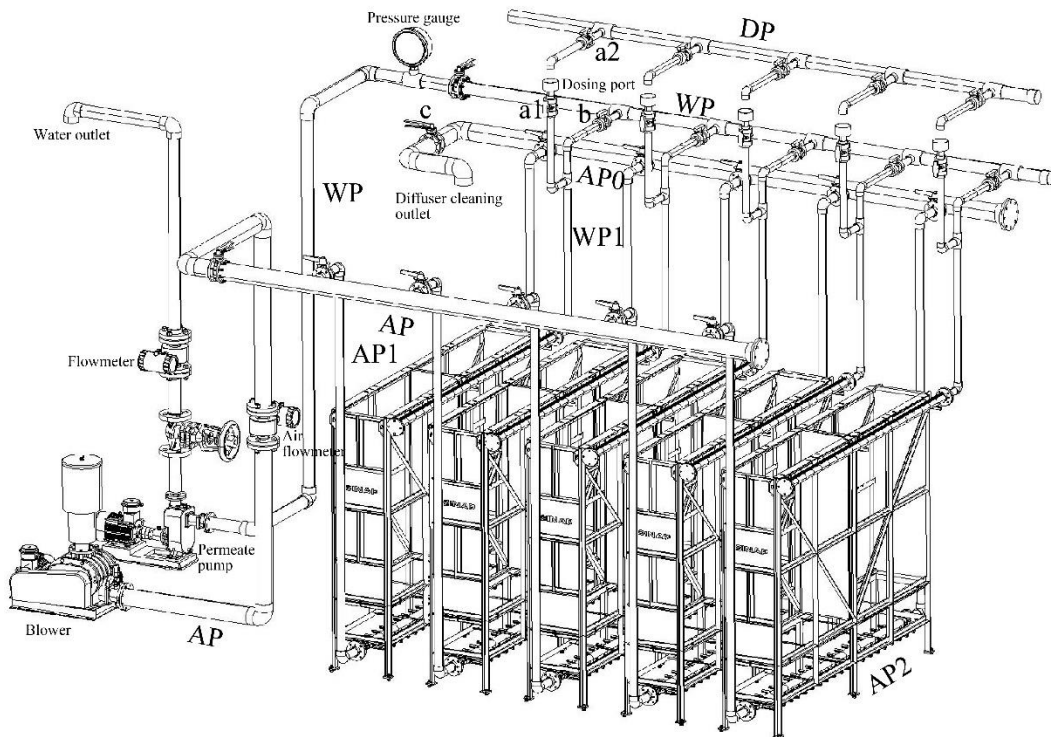

(b) Membrane system pipeline connection method two (branch pipe cleaning chemical dosing)

Figure 5-11 Membrane module pipeline design

AP: Main air pipe

DP: Main dosing pipe

AP₁: Branch Air pipe

a₁: Chemical cleaning valve

AP₂: Diffuser (Offered by SINAP)

a₂: Chemical cleaning valve

WP: Main permeate pipe

b: Permeate valve

WP₁: Branch permeate pipe

c: Diffuser cleaning valve

AP₀: Main diffuser cleaning pipe

Announcements :

Notice! Diffuser cleaning valve should set here easy to operate.

Notice! Single membrane tank can set single dosing port to ensure air impermeability of pipeline.

Notice! Air stand pipe has a certain length need to make effective immobilization to ensure the connection and air pipe will not damage in long terms shocking and harm to the whole system. SINAP will not assume responsibility if membranes damaged by this situation.

5.14 Membrane system supporting equipment

Users need to prepare membrane system supporting equipment by themselves. Equipment selection and use suggestions in this manual are for reference only.

Membrane system main supporting equipment show in table 5.9 (purchased by buyer):

Table 5.9 MBR membrane system supporting equipment

	Equipment		Remark
一、Aeration system			
1.1	Membrane system blower		
1.2	Air flowmeter		
1.3	Diffuser cleaning valve		
二、Permeate system			
2.1	Pump	2.1.1 Self-priming pump (Method one)	Selection according to customer needs
		2.1.2 Vacuum pumping system + centrifugal pump (Method two and three)	
2.2	Permeate flowmeter		
2.3	Vacuum manometer		Before pump
2.4	Sampling valve		After pump
2.5	On-line turbidity meter		After pump
三、Membrane cleaning system			
3.1	Dosing funnel		Acid/alkali cleaning
3.2	Dosing tank		
3.3	Dosing metering pump (optional)		
3.4	Emptying valve		
四、Autonomous system			
4.1	Electric control cabinet		Water level control, permeate system control, aeration system control
4.2	Cable		

5.14.1 Aeration system

5.14.1.1 MBR blower

Blower need to meet the aeration volume and air pressure requirement of membrane system. If do not have enough aeration will cause serious pollution of membrane elements; If aeration over limit will cause membrane damage. (Aeration volume please see table 5.8)

5.14.1.2 Air flow meter

It is recommended to set an air flow meter on the main air pipe to monitor and adjust aeration volume. (volume set according to the membrane quantity)

5.14.1.3 Diffuser cleaning valve

During operation, dry air will made dry sludge block holes of diffuser. The blockage will cause aeration reduce and nonuniformity lead to the membrane fouling by lack of aeration scour then reduce capacity. Therefore, the aerator should be cleaned regularly. (Show in figure 5-12)

The diffuser cleaning valve should be set in the position that is convenient for manual operation. If use automatic valve, can do daily cleaning and time can be set at about 5 minutes. If the cleaning effect is not obvious, the cleaning time should be extended.

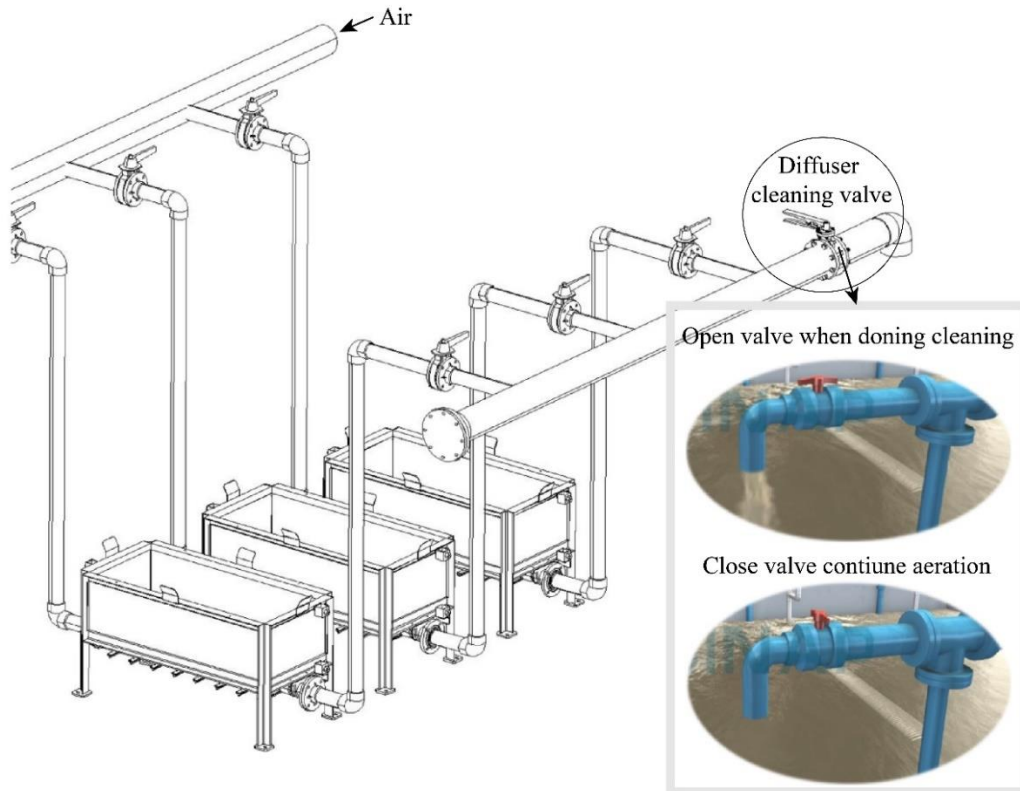

Figure 5-12 Diffuser cleaning

5.14.2 Permeate system

Membrane system use negative pressure method to produce water. It needs suction pump, vacuum pressure gauge, liquid level gauge, flow meter and valves.

5.14.2.1 Suction pump

Suction pump of membrane system normally chooses self-priming pump suction 4~6m. Consider lose in pipeline, when choose suction pump need to have some margin on suction and capacity; operate and rest time may need to adjust on real situation to have best operate condition.

Notice! If suction pump set lower than water level, it needs to set electric check valve to prevent siphonage; If suction pump set higher than water level, it needs to set non-return valve.

Warning! When design automatic control system, it should be noted that when the aeration is stopped or doing diffuser cleaning, the suction pump must be stop to prevent the membrane element from serious fouling and blocking.

5.14.2.2 Permeate method

According to the requirements on site, the following three methods can be adopted:

Method one: Middle and small system use self-priming pump

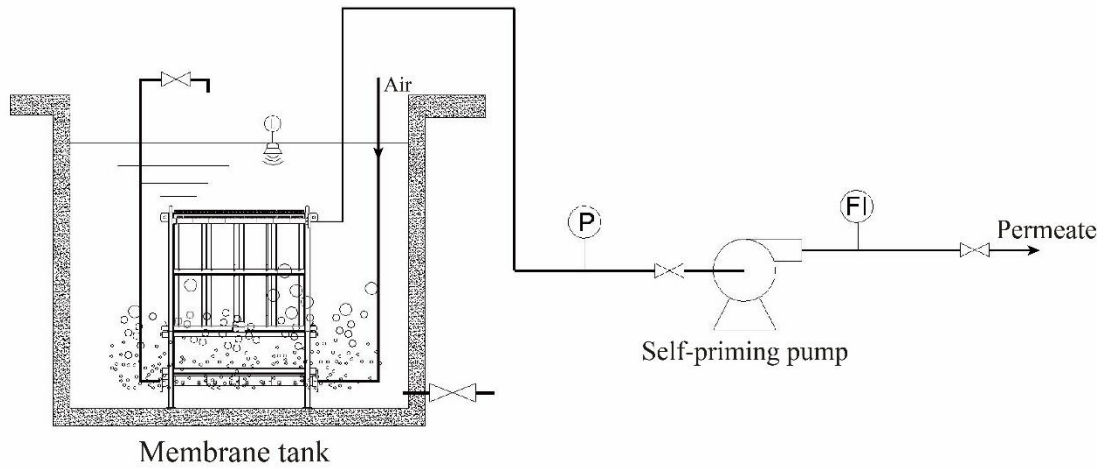

Figure 5-13 Self-priming pump option

Method two: Middle and big system use vacuum generator + centrifugal pump
(details consult suppliers)

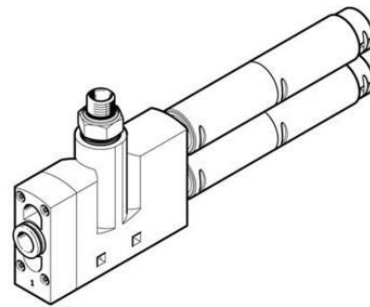

Figure 5-14 Vacuum generator

Method: Big system use vacuum pumping system + centrifugal pump (vacuum pumping system please consult suppliers)

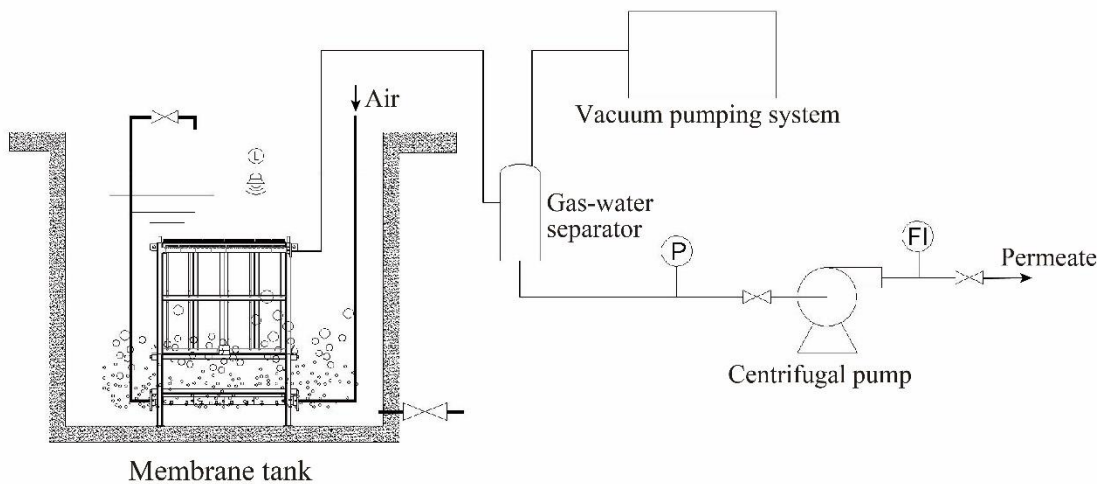

Figure 5-15 Centrifugal pump option

5.14.2.3 Vacuum manometer

Set vacuum manometer before suction pump to monitor membrane fouling. Its recommended to set the vacuum manometer on the same level of water level in membrane tank.

During normal operation, its need to clean the membrane when TMP reach -25kPa; stop system when TMP reach -30 kPa.

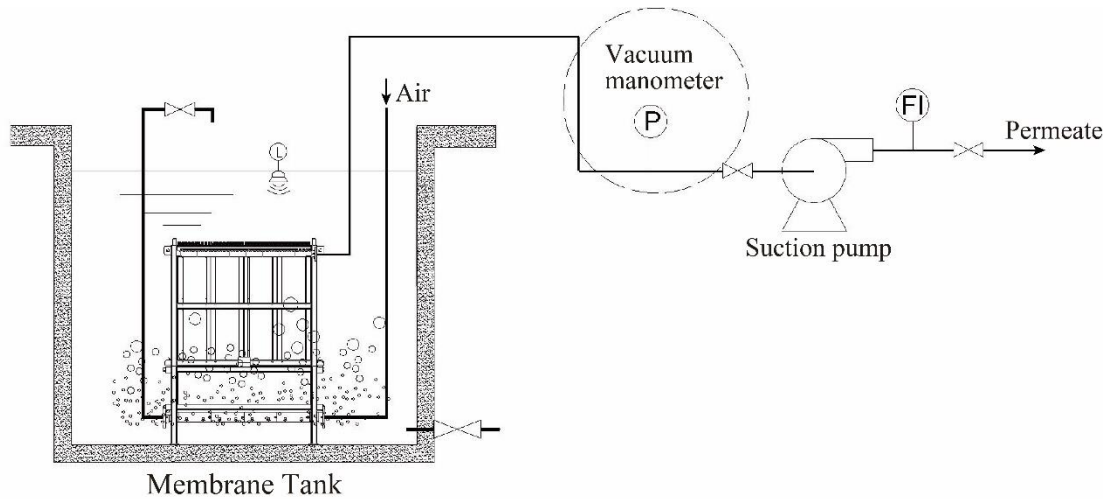

Figure 5-16 Vacuum manometer setting position (recommend)

5.14.2.4 Permeate flowmeter

Set permeate flowmeter on the outlet side of suction pump to monitor and control flux. Multiple membrane modules can use one set flow control system.

5.14.3 Membrane clean system

5.14.3.1 Cleaning equipment and dosage

Dosing port is needed work with dosing tank or metering pump; Cleaning agent dosage is shown in the table 5.10.

Table 5.10 Cleaning agent dosage

Name	Concentration	Membrane series	Dosage (L/pc)
NaClO	0.5% ("Active chlorine" content)	SINAP80	3.0
		SINAP100	3.5
		SINAP150	5.0
Oxalic acid	1%	SINAP80	3.0
		SINAP100	3.5
		SINAP150	5.0

5.14.3.2 Cleaning on-site methods

Method one: **Gravity dosing**, fit dosing tank set above water level of membrane tank.

(Show in figure 5-17)

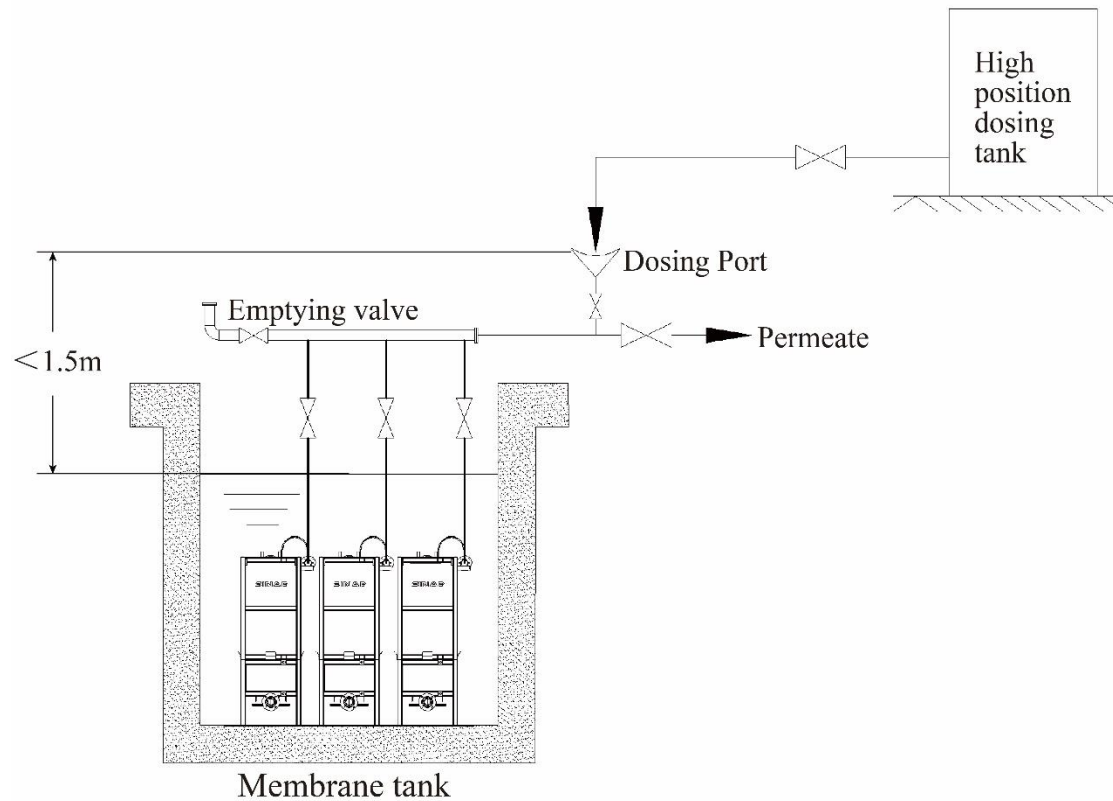

Figure 5-17 Gravity dosing

Method two: **Pump lift**, fit dosing tank set below water level of membrane tank. (Show in figure 5-18)

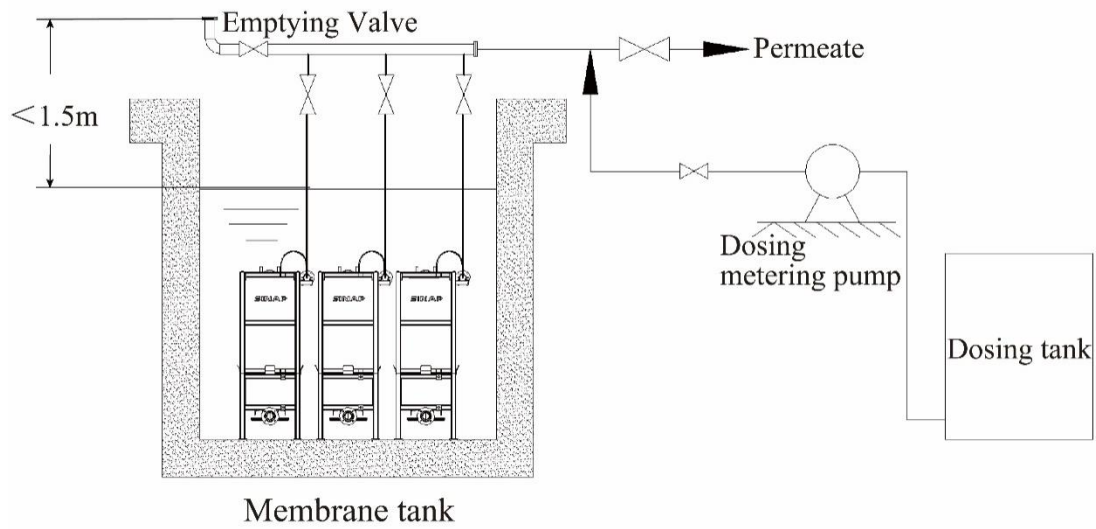

Figure 5-18 Pump lift dosing

Method three: **Online dilution dosing**. Use dosing metering pump and dilution water pump to dilute cleaning agent in in-line mixer. (Show in figure 5-19) If chemical cleaning on-site in this way, please contact us for details.

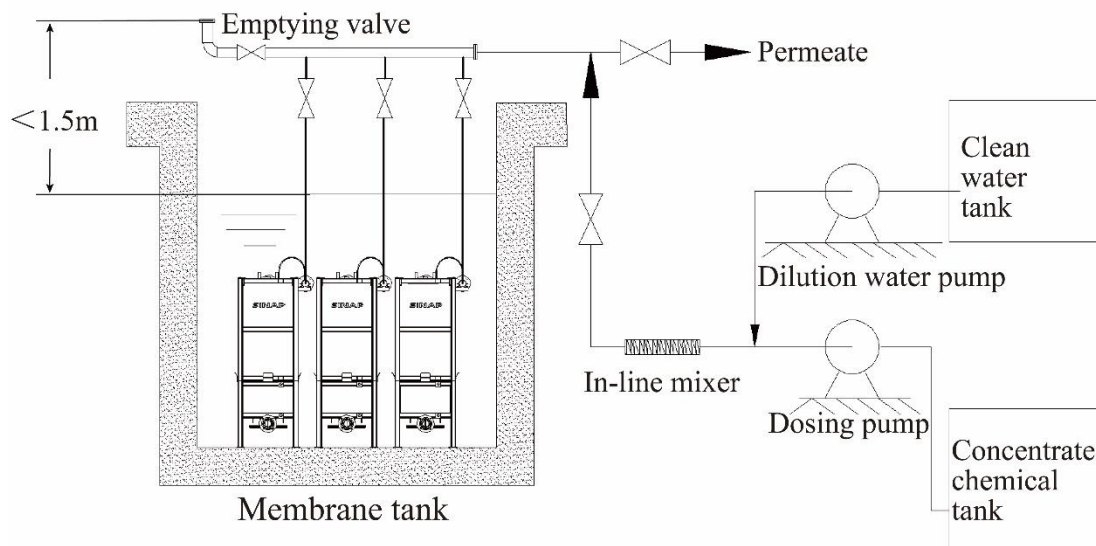

Figure 5-19 Online dilution dosing

5.15 Autonomous system

This autonomous system here only membrane system control, other part of autonomous system needs to design by user themselves. Electric control cabinet control suction pump, blower, diffuser cleaning valve, liquidometer and other equipment. Control point show in table 5.11 or consult the technical personnel of SINAP.

5.15.1 Membrane operate and cleaning process

Table 5.11 Membrane operate and cleaning process control point*

Process	SN	Action	Time (min)	Suction pump	Blower	Permeate	Diffuser cleaning valve	Emptying valve	Dosing valve	Dosing pump	Remark
1.Permeate	1-1	Permeate	8	√	√	√	×	×	×	×	Working pattern (can be adjust)
	1-2	Stop permeate	2	×	√	×	×	×	×	×	
2.Diffuser cleaning	2-1	Clean the diffuser	5	×	√	×	√	×	×	×	One time every day, go into1-1 after this process
3.Chemical cleaning	3-1	Dosing	30~45	×	×	×	×	√	√	√	TMP ≥-25kPa
	3-2	Steep	120~240	×	×	×	×	√	×	×	Or every 3-6 months, go into1-1 after this process

*Note: “√” means open, “×” means close.

5.15.2 Autonomous process and description

(1) Normal operate process

① Membrane system starting process: open blower, start aeration for 30min then start suction pump, open permeate valve last; suction pump operate pattern is operate 8 min and rest 2 min (can be adjust). When water level in membrane tank reach warning level (Warning level controller is installed more than 300mm above the membrane module) stop suction pump;

② When blower fails or stops suction pump stops;

③ If the membrane system does not run for a long time, the blower needs work 40min in every 2 hours;

Note: At first start membrane system, it is necessary to manually empty the air in the pipe or automatically start the supporting vacuum equipment to make the membrane system produce water normally.

(2) Diffuser cleaning process

① Diffuser need do a cleaning every 24 hours;

② Close permeate valve then close suction pump;

③ Blower continue operation, open diffuser cleaning valve, clean by 5~8 min;

④ Close diffuser cleaning valve, start suction pump, open permeate valve and back to normal operate.

(3) Chemical cleaning process

① When TMP reach -25kPa or membrane flux getting lower than 90% of design flux or operated 6 months needs to alarm alert to clean the membrane module;

② Close permeate valve, stop suction pump and stop blower;

③ Open dosing pump, open dosing valve, open emptying valve, release pressure in the piping line to let cleaning agent flow into membrane elements.

④ Dosing pump work 30~45min, waiting for cleaning agent empty then close dosing valve, close dosing pump.

⑤ After membrane module steeked 2~4 hours close emptying valve then open blower, suction pump, permeate valve in turns and back to normal operation;

Notice!

Normal operation and the chemical cleaning procedure can be switched manually or automatically according to the actual situation.

6. SINAP membrane module lifting

6.1 Lifting height of membrane module

Design lifting height of membrane module according to the membrane tank depth and module type.

(1) **Lift without empty membrane tank.** Use SINAP special lifting tool with guide rail and guide chain, etc (show in figure 6-1).

Lifting height calculation formula:

$$H_1 = H + D_1 + 2300 \quad \dots\dots\dots (6-1)$$

Explain: H_1 : Minimum lifting height (mm)

H : Height of membrane case (mm)

D_1 : Length of guide chain (mm) **(If double deck module uses**

lower guide chain length)

Notice! If design to use removeable railings, the minimum lifting height= H_1 - railing height.

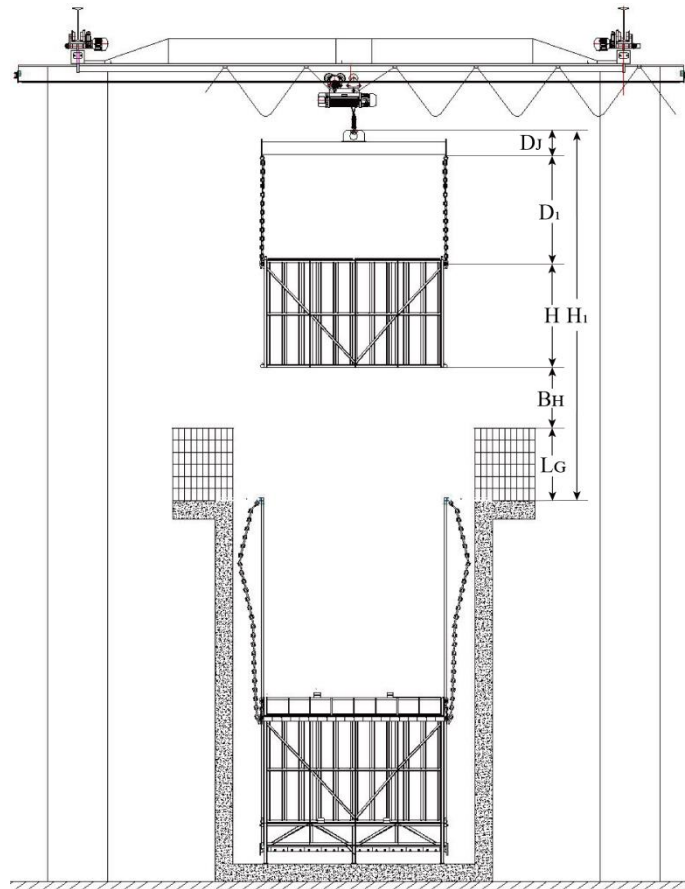

L_G : Railing height;
 B_H : Protect height;

D₁: Length of guide chain;

D₂: Lifting tool height;

H: Height of membrane case;

Figure 6-1 Lift without empty membrane tank (unit: mm)

(2) **Lift after empty membrane tank.** Use SINAP special lifting tool (show in figure 6-2)

Lifting height calculation formula:

$$H_1 = H + 2800 \quad \dots\dots\dots (6-2)$$

Explain: H_1 : Minimum lifting height (mm)

H: Height of membrane case (mm)

Notice! If design to use removeable railings, the minimum lifting height= H_1 - railing height.

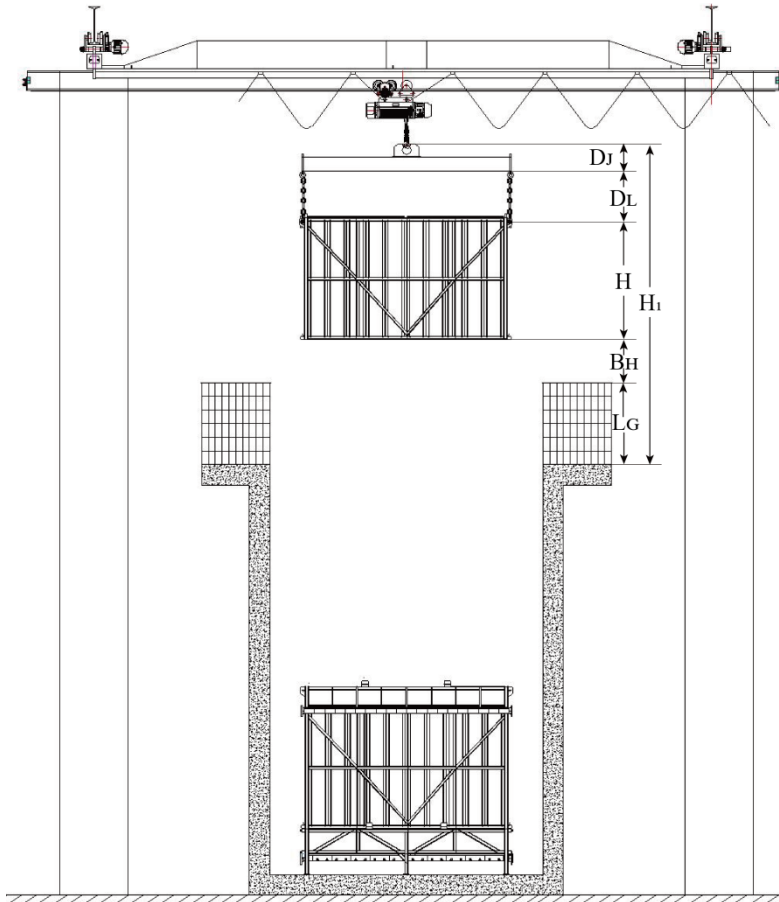

- L_G: Railing height;
- B_H: Protect height;
- D₁: Length of guide chain;
- D_J: Lifting tool height;
- H: Height of membrane case;

Figure 6-1 Lift after empty membrane tank (unit: mm)

6.2 Lifting load of membrane module

Lifting load of membrane module reference to table 6.1, 6.2 wet weight of membrane case.

Table 6.1 Weight of single deck membrane case

Type	Dry weight (Kg)	Wet weight *(Kg)	Type	Dry weight (Kg)	Wet weight *(Kg)
SINAP80-60	242	485	SINAP80-120	520	1040
SINAP80-80	315	630	SINAP80-160	665	1330
SINAP80-100	395	790	SINAP80-200	830	1660
SINAP100-60	310	620	SINAP100-120	635	1270
SINAP100-80	405	810	SINAP100-160	755	1510
SINAP100-100	508	1016	SINAP100-200	1075	2150
SINAP150-100	725	1450	SINAP150-160	1155	2310
SINAP150-120	855	1710	SINAP150-200	1435	2870

Note: *Wet weight is the weight of the membrane case in the limit state

Table 6.2 Weight of double deck membrane case

Type	Dry weight (Kg)		Wet weight *(Kg)
	Upper membrane case	Lower membrane case	
SINAP80-100D	380	400	800
SINAP80-200D	768	807	1620
SINAP100-100D	497	515	1030
SINAP100-200D	937	972	1950
SINAP150-100D	817	856	1710
SINAP150-200D	1417	1456	2910

Note: *Wet weight is the weight of the membrane case in the limit state

7. Attachment: membrane module boundary and installation dimensions

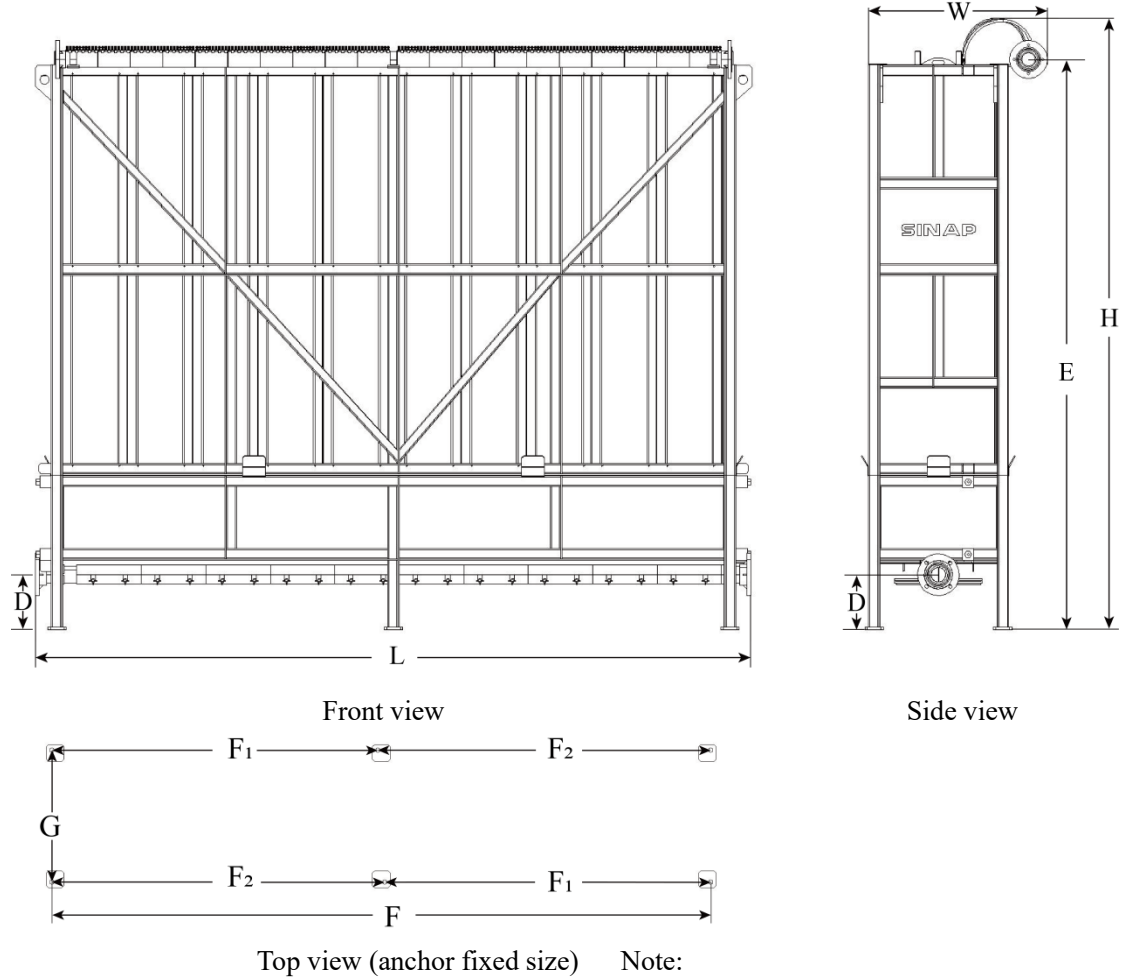

Figure 7-1 Single deck membrane module three view drawing

Single deck membrane module dimensions show in table 7.1:

Table 7.1 Single deck membrane module boundary and installation dimensions

Type	Dimensions (mm)								Manifold flange/dimensions	Diffuser flange/dimensions
	L	W	H	D	E	F	F ₁ /F ₂	G		
SINAP80-60	1090	760	1900	238	1630	935	/	588	DN32	DN65
SINAP80-80	1380					1220	/			
SINAP80-100	1660				1720	1500	/		DN50	
SINAP80-120	1940					1785	/			
SINAP80-160	2540					2385	1210/1180			
SINAP80-200	3110					2950	1490/1460			
SINAP100-60	1090	760	2150	238	1885	935	/	588	DN32	
SINAP100-80	1380					1220	/			
SINAP100-100	1660				1970	1500	/		DN50	
SINAP100-120	1940					1785	/			
SINAP100-160	2540					2385	1210/1180			
SINAP100-200	3110					2950	1490/1460			
SINAP150-100	1660	760	2650	238	2470	1500	/	588	DN50	
SINAP150-120	1940					1785	/			
SINAP150-160	2540					2385	1210/1180			
SINAP150-200	3110					2950	1490/1460			

✧ Manifold and diffuser flange are all standard ABS flange;
 ✧ SINAP80, SINAP100 and SINAP150 series: The height of the membrane case is fixed, diffuser case can adjust in range 500mm-700mm;
 ✧ Error (±2mm) The actual size is subject to the real object, data in this table is only for design reference;

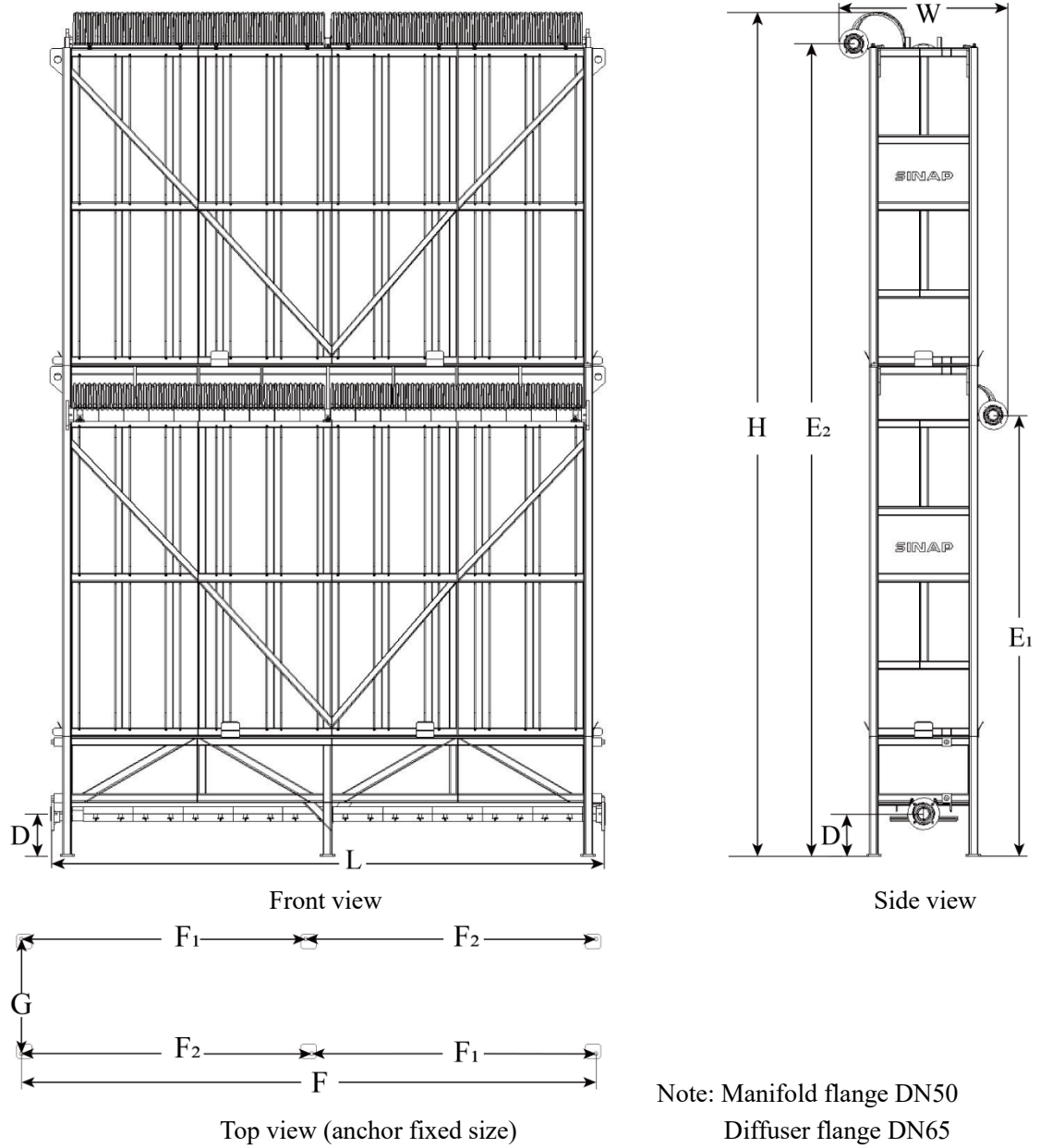

Figure 7-1 Double deck membrane module three view drawing

Double deck membrane module dimensions show in table 7.2

Table 7.2 Double deck membrane module boundary and installation dimensions

Type	Dimensions (mm)								Manifold flange/dimensions	Diffuser flange/dimensions
	L	W	H	D	E ₁ /E ₂	F	F ₁ /F ₂	G		
SINAP80-100D	1660	910	3280	238	1720/3050	1500	/	588	DN50	DN65
SINAP80-200D	3110					2950	1490/1460			
SINAP100-100D	1660	910	3780	238	1970/3550	1500	/	588		
SINAP100-200D	3110					2950	1490/1460			
SINAP150-100D	1660	910	4780	238	2470/4550	1500	/	588		
SINAP150-200D	3110					2950	1490/1460			
✧ Manifold and diffuser flange are all standard ABS flange; ✧ SINAP80, SINAP100 and SINAP150 series: The height of the membrane case is fixed, diffuser case can adjust in range 500mm-700mm; ✧ Error (±2mm) The actual size is subject to the real object, data in this table is only for design reference;										